

Liquid-Propellant Rocket Engine Throttling: A Comprehensive Review

Matthew J. Casiano*

NASA Marshall Space Flight Center, Huntsville, Alabama 35812

James R. Hulka[†]

Jacobs Engineering, Huntsville, Alabama 35812

and

Vigor Yang[‡]

Georgia Institute of Technology, Atlanta, Georgia 30332

DOI: 10.2514/1.49791

Liquid-propellant rocket engines are capable of on-command variable thrust or thrust modulation, an operability advantage that has been studied intermittently since the late 1930s. Throttleable liquid-propellant rocket engines can be used for planetary entry and descent, space rendezvous, orbital maneuvering including orientation and stabilization in space, and hovering and hazard avoidance during planetary landing. Other applications have included control of aircraft rocket engines, limiting of vehicle acceleration or velocity using retrograde rockets, and ballistic missile defense trajectory control. Throttleable liquid-propellant rocket engines can also continuously follow the most economical thrust curve in a given situation, as opposed to making discrete throttling changes over a few select operating points. The effects of variable thrust on the mechanics and dynamics of an liquid-propellant rocket engine as well as difficulties and issues surrounding the throttling process are important aspects of throttling behavior. This review provides a detailed survey of liquid-propellant rocket engine throttling centered around engines from the United States. Several liquid-propellant rocket engine throttling methods are discussed, including high-pressure-drop systems, dual-injector manifolds, gas injection, multiple chambers, pulse modulation, throat throttling, movable injector components, and hydrodynamically dissipative injectors. Concerns and issues surrounding each method are examined, and the advantages and shortcomings compared.



Matt Casiano has been an Aerospace Engineer at NASA Marshall Space Flight Center since 2000. He received his Ph.D. from the Pennsylvania State University and his M.S. in Mechanical Engineering from Georgia Institute of Technology. He was the recipient of a Silver Snoopy in 2009 for fluid dynamics work performed during the investigation of the Space Shuttle flow control valve. He has worked in the area of rocket propulsion focusing on acoustics, unsteady fluid dynamics, signal analysis, and combustion instability as a part of the fluid dynamics branch in support of launch vehicle and engine design and development.



Jim Hulka is an Engineering Specialist at Jacobs Engineering supporting the combustion devices component design and development group at the NASA Marshall Space Flight Center, currently working on design and development of the J-2X engine as well as oxygen/hydrogen and oxygen/methane engines for future in-space vehicles. Previously he worked at Aerojet General Corporation in design, analysis and test of combustion devices and engine systems for many liquid propellant rocket engine development and research programs. He has an M.S. in Aerospace Engineering from the Pennsylvania State University.



Vigor Yang, William R. T. Oakes Professor and Chair of the School of Aerospace Engineering at the Georgia Institute of Technology, received his Ph.D. from the California Institute of Technology. Prior to joining the faculty at GIT, he was the John L. and Genevieve H. McCain Chair in Engineering at the Pennsylvania State University. He was the recipient of the Penn State Engineering Society Premier Research Award, and several publication and technical awards from AIAA, including the Air-Breathing Propulsion Award in 2005, the Pendray Aerospace Literature Award in 2008, and the Propellants and Combustion Award in 2009. He has been a consultant to many U.S. rocket and gas-turbine engine companies as well as government organizations.

Presented as Paper 2009-5135 at the 45th AIAA/ASME/SAE/ASEE Joint Propulsion Conference and Exhibit, Denver, CO, 2–5 August 2009; received 15 March 2010; revision received 8 May 2010; accepted for publication 10 May 2010. Copyright © 2010 by the American Inst. of Aeronautics and Astronautics, Inc. The U.S. Government has a royalty-free license to exercise all rights under the copyright claimed herein for Governmental purposes. All other rights are reserved by the copyright owner. Copies of this paper may be made for personal or internal use, on condition that the copier pay the \$10.00 per-copy fee to the Copyright Clearance Center, Inc., 222 Rosewood Drive, Danvers, MA 01923; include the code 0748-4658/10 and \$10.00 in correspondence with the CCC.

*Aerospace Engineer, Propulsion Systems Department, Mailstop ER42, Senior Member AIAA.

[†]Engineering Specialist, ESTS Group, Propulsion Systems Department, Mailstop ER32, Senior Member AIAA.

[‡]William R. T. Oakes Professor and Chair, School of Aerospace Engineering, 313 Montgomery Knight Building. Fellow AIAA.

Nomenclature

A	=	empirical constant
A_e	=	nozzle exit area
B	=	empirical constant
c^*	=	characteristic exhaust velocity
D_{30}	=	volume mean droplet diameter
D	=	jet diameter
E_m	=	Rupe mixing efficiency
F_T	=	thrust
L^*	=	characteristic length
\dot{m}	=	mass flow rate
MR	=	mixture ratio
p_a	=	ambient pressure
p_c	=	chamber pressure
p_e	=	nozzle exit pressure
v_e	=	nozzle exit velocity
V	=	jet velocity
Δp_{inj}	=	injector pressure drop
ΔV	=	delta- v
η_{c^*}	=	characteristic exhaust velocity efficiency

I. Introduction

LIQUID-PROPELLANT rocket engines (LREs) with thrust that can be varied on demand have been researched and studied since the late 1930s. The Vision for Space Exploration [1], outlined in the NASA Authorization Act of 2005 [2], brought a renewed interest in such throttle-capable LREs. The Act established a program to develop a sustained human presence on the moon as a stepping stone to future exploration of Mars and other remote destinations [2]. Throttleable LREs will undoubtedly play a significant role in these missions, so understanding the dynamics of throttling LREs as well as the physics and engineering issues of the throttling process will be of critical importance for the success of these missions. This review provides a detailed survey of LRE throttling, focusing primarily on engines from the United States.

The term *throttling* is commonly used to describe a varying thrust profile or thrust modulation in an LRE. This nomenclature is used primarily because one of the most common methods of thrust control in an LRE is from regulation of propellant flow rates by control valves, as throttling is typically defined. A throttleable LRE that continuously follows the most economical thrust curve provides optimum vehicle performance, as compared with one that undergoes discrete throttling changes over some portion of the rated power level. The continually changing thrust can reduce the amount of propellants required for a mission, thus reducing the mass of the vehicle. While throttling an LRE is a critical requirement during a lunar descent, there are many other applications for throttleable LREs. The most common use of throttling is to limit the acceleration in upper stage engines of launch vehicles toward the end of their burns via valve control. Throttleable LREs can also be used for planetary entry and descent, space rendezvous, orbital maneuvering including orientation and stabilization in space, and hovering and hazard avoidance during planetary landing [3–5]. Other applications include control of aircraft rocket engines, limiting of vehicle acceleration or velocity using retrograde rockets, and ballistic missile defense trajectory control [5,6]. An early attempt at estimating throttling requirements for several such missions reported examples such as 10-to-1 throttling for lunar descent, 1.3-to-1 for Venus launch, and up to 100-to-1 for ballistic missiles and orbital rendezvous, with generally higher throttling ratios for more precise trajectory control [7,8]. LREs can be customized for particular flight applications, including a wide range of thrust values, quick restarts, fast pulsing, and quick attitude changes and minor velocity changes. References [3,9] describe other benefits of LREs, in general, including on-command thrust modulation, which allows further tailoring of the flight application. While tailoring thrust profiles of rocket engines with solid propellants has become more flexible in recent years, it is still much simpler to develop randomly commanded controllable thrust profiles for LREs, since the combustion process is easier to control, stop, and restart.

Throttleable LREs were originally developed in Germany in the late 1930s during rocket aircraft experiments and research headed by Major-General Dr. Walter Dornberger (then Major) and Hellmuth Walter. Before 1937, LREs had been used by the early pioneers for experimental and meteorological research rockets; these LREs operated at essentially constant thrust [3]. The first aircraft to incorporate LREs for propulsion during a portion of the flight was most likely the German Heinkel He 112 fighter aircraft in early 1937 at Neuhardenberg airfield, powered by a version of an A2 (Aggregate 2) rocket motor [10,11]. This rocket motor, designed by Dr. Werner von Braun, was fitted to the He 112 aircraft and fueled from nitrogen-pressurized alcohol and liquid oxygen tanks [11]. This probably took place, although there are reports and testimonies that describe conflicting dates, places, and events during the mid-to-late 1930s [12–18]. The aircraft, engine, and date of the first rocket powered aircraft flight are, however, corroborated by testimony from Heinkel, Dornberger, and von Braun [11]. In November of 1937, another Heinkel He 112 aircraft was flown at Neuhardenberg. During a portion of its flight it used a TP-1 (Turbopump-1) rocket engine, designed and built by Hellmuth Walter. An 80%-concentration solution of H_2O_2 (20% concentration H_2O) was forced into the combustion chamber and mixed with a spray catalyst (water solution of sodium or calcium permanganate). A manual pilot-operated stop-cock pneumatically regulated the flow of the H_2O_2 solution to the combustion chamber [11]. The maximum thrust was 220 lb.. The amount of throttling is unknown, but this was the first known rocket engine to incorporate manual thrust throttling [17,19]. In April of 1938, the Heinkel He 112 became the first aircraft to be powered by rocket thrust alone through its entire takeoff and flight at Peenemünde West airfield, using the throttleable Walter-designed TP-1 engine [11,19]. Robert Goddard arguably implemented the first practical throttleable liquid bipropellant engines in the U.S. during the early 1940s [3,19]. The research on throttling engines, after this pioneering work, focused on applicability to missile defense, weapons systems, and then space vehicles [7,8,20].

Several methods have been identified to control thrust of an LRE. In 2006, Dressler described nine methods that had been used in past configurations [19]. Many of these methods were described conceptually as early as 1950 [21] and several others in 1963 [7]. A number of the methods are also discussed in Russian texts, with attention to the details of injector element design. The nine methods mentioned in [19] will be discussed in more detail in this paper.

There are only a few physical parameters that can be varied to change the thrust of a single engine, including the propellant types or compositions, the propellant flow rates, the nozzle exit area, and the nozzle throat area. The propellants and nozzle exit area are difficult to control or vary due to physical restrictions, while the nozzle throat area is difficult to vary if the heat fluxes are high. Consequently, varying the propellant flow rates is the simplest recourse for varying thrust. The simple relationship between thrust and propellant flow rates comes from the rocket thrust equation

$$F_T = \dot{m} \cdot v_e + (p_e - p_a) \cdot A_e \quad (1)$$

This paper discusses several LRE throttling methods, including high-pressure-drop systems using propellant flow regulation, dual-manifold injectors, gas injection, multiple chambers, pulse modulation, throat throttling, movable injector components, and hydrodynamically dissipative injectors. Several significant projects and studies are discussed. Critical issues such as combustion instability [22,23], performance degradation, and excessive heat transfer are examined for each method. Any further concerns and issues surrounding each method are examined, and the advantages and shortcomings of the different methods are compared.

II. Discussion

A top level summary of pertinent information from the reviewed projects, research tasks, and investigations is presented in Table 1. The following sections review the throttling methods.

Table 1 Summary of information from reviewed projects, research tasks, and investigations

Throttling methodology	Program	Program period	Organizations	Engine/rocket designations	Operating parameters	Throttling	Propellant combinations/injector type	Throttling related research focus
High-pressure-drop injector	Project Thumper	1948–1949	1) General Electric 2) U.S. Army	Malta engine	1000 lbs rated thrust, 315 psia rated p_c	10–104%	1) Ethanol (with silicone)/LO ₂ 2) Malta low-pressure-drop injector 3) High-pressure-drop showerhead	Pursue development of high-altitude antiaircraft defense
High-pressure-drop injector	Project MX-794	1950	1) Willow Run Research Inst., Univ. of Michigan 2) U.S. Air Force	1) Engine 0073 2) Engine 0150 3) Engine 0151	1) 1000 lb rated thrust, 300 psia rated p_c , 2.75 MR 2) 200 lbs rated thrust, 300 psia rated p_c , 2.75 MR	1) 10% to 167% 2) 33% to 210% 3) 2.25 < MR < 5.0	1) 80% RFNA and 20% aniline/furfuryl alcohol 2) JP-3 (AN-F-58a) (with aniline leader)/RFNA 3) Doublet and OFO triplet	Obtain performance for defense systems
High-pressure-drop injector	NASA Study	1964	1) NASA Lewis Research Center 2) Pratt and Whitney Aircraft	Modified RL10A 1	15,000 lb rated thrust, 300 psia rated p_c , 5.0 MR	1) 3.3–100% 2) 2.0 < MR < 6.0	1) LH ₂ /LO ₂ 2) Swirl coax: 20% ox pressure drop 3) Shear coax: 33% ox pressure drop 4) Swirl coax: 60% ox pressure drop	Obtain steady-state and dynamic characteristics during throttling
High-pressure-drop injector	ARES Throttling-Scaling Design Study Program ^a	1967–1969	1) Aerojet-General Corp. 2) Air Force Rocket Propulsion Lab. 3) NASA Marshall Space Flight Center	ARES Engine Design ^a	25,000, 100,000, or 500,000 lb rated thrust, 2800 psia rated p_c ^a	1) 10-to-1 ^a 2) 33-to-1 ^a	1) A-50/N ₂ O ₄ ^a 2) HIPERTHIN platelet ^a	Design a throttleable and restartable engine
High-pressure-drop injector	DC-X and DC-XA	1991–1995	1) Pratt and Whitney 2) McDonnell Douglas 3) NASA	RL10A-5	13,500 lb rated thrust, 485 psia rated p_c , 6.0 MR	1) 3.3-to-1 2) 5.0 < MR < 6.0	1) LH ₂ /LO ₂ 2) Swirl coax	Single-stage to orbit rocket technology demonstrator
High-pressure-drop injector	Joint Cooperative Study	1996	1) NASA Marshall Space Flight Center 2) Aerojet 3) Chemical Automatics Design Bureau	RD-0120	441,000 lb rated thrust, 3170 psia rated p_c , 6.0 MR	1) 25–100% 2) 3.7 < MR < 6.4	1) LH ₂ /LO ₂ 2) Shear coax	Potential use for the X-33 demonstrator vehicle propulsion system
High-pressure-drop injector	Joint Cooperative Study	1997	1) Boeing Rocketdyne 2) NASA Marshall Space Flight Center	SSME	470,000 lb rated thrust, 3006 psia rated p_c , 6.0 MR	1) 17–109% 2) 5.0 < MR < 6.0	1) LH ₂ /LO ₂ 2) Swirl coax	Potential use for the X-33 demonstrator vehicle propulsion system
High-pressure-drop injector	Common Extensible Cryogenic Engine	2005–2010	1) Pratt and Whitney Rocketdyne 2) NASA	Modified RL10	13,700 lb rated thrust, 381 psia rated p_c , 5.6 MR	1) 5.9–104% 2) 2.9 < MR < 6.0	1) LH ₂ /LO ₂ 2) Swirl coax	Technology development, demonstration, risk reduction, and maturation of a deep throttling, highly reliable, reusable cryogenic engine

(continued)

Table 1 Summary of information from reviewed projects, research tasks, and investigations (Continued)

Throttling methodology	Program	Program period	Organizations	Engine/rocket designations	Operating parameters	Throttling	Propellant combinations/injector type	Throttling related research focus
Dual-manifold injector	Advanced throttling concepts studies	1963–1966	1) Pratt and Whitney Aircraft 2) United Technology Center 3) U.S. Air Force	Research engine	1) 15,000 lb rated thrust, 300 psia rated p_c , 1.7 MR 2) 1000 lb rated thrust 3) 8500 lb rated thrust	1) 0.8–08% 2) 12.8-to-1 3) 29.4-to-1	1) A-50/N ₂ O ₄ 2) H ₂ /F ₂ 3) BA1014/F ₂ ^a 4) Triplet element 5) Quadruplet element	Evaluate injector systems that provide high combustion performance during deep throttling
Dual-manifold injector	Chamber Technology for Space Storable Propellants	1964–1969	1) Rocketdyne 2) NASA	Research engine	1000 lb rated thrust, 100 psia rated p_c , 2.0 MR	15–150%	1) MMH, butene-1, and diborane/FLOX 2) Oxygen difluoride 3) Impinging	Develop design criteria for selected space storable fuels
Dual-manifold injector	Reusable Rocket Engine Program	1967–1972	1) Pratt and Whitney Aircraft 2) Air Force Rocket Propulsion Lab.	1) Advanced cryogenic engine 2) XLR-129-P-1	1) 250,000 lb rated thrust 2) 2740 psia main chamber rated p_c 3) 4793 psia preburner rated p_c	1) 5-to-1 2) $5 < MR < 7$ main injector 3) $0.72 < MR < 1.26$ preburner	1) LH ₂ /LO ₂ 2) Stacked tangential inlet	Demonstrate performance and mechanical integrity of rocket engine
Dual-manifold injector	Throttleable Primary Injector for Staged Combustion Engine Program	1968–1970	1) Aerojet-General Corp. 2) Air Force Rocket Propulsion Lab.	MIST derived	50,000 lb rated thrust	10%	1) A-50/N ₂ O ₄ 2) HIPERTHIN platelet, impinging oxidizer/impinging fuel	Develop design criteria for selected space storable fuels
Dual-manifold injector	Advanced Expander Test Bed Program	1990–1993 1996–1997	1) Pratt and Whitney 2) NASA	Expander cycle engine	1) 20,000 lb rated thrust 2) 25,000 lb rated thrust	Proprietary	1) H ₂ /LO ₂ 2) swirl coax	Develop and demonstrate an expander cycle oxygen-hydrogen engine technology applicable for space engines
Gas injection	NACA Research	1956–1957	NACA Lewis Flight Propulsion Lab.	Research engine	1) 1000 lb rated thrust 2) Helium gas	1) 34–89% 2) $1.3 < MR < 2.4$	1) NH ₃ (with lithium)/WFNA 2) Doublet	Investigation into gas injection throttling
Gas injection	Feasibility Study and Experimental Program	1963	United Technology Center	Research engine	1) 500 lb rated thrust, 300 psia p_c 2) 500 lb rated thrust, 150 psia p_c 3) Helium gas	6–223%	1) MMH/MON-15 2) A-50/N ₂ O ₄ 3) Triplet FOF, duo-doublet FOOF, showerhead, 25% showerhead/75% duo-doublet	Investigation into gas injection throttling using various injection concepts
Gas injection	LMDE Concept	1963–1965	Rocketdyne	SE-10	1) 10,500 lbs rated thrust 2) Helium gas	10-to-1	A-50/N ₂ O ₄	Competing Apollo lunar descent engine
Gas injection	NASA Study	1964	1) NASA Lewis Research Center 2) Pratt and Whitney Aircraft	RL10A-1	1) 15000 lbs rated thrust, 300 psia rated p_c , 5.0 MR 2) Helium gas, oxygen gas	10-to-1	1) LH ₂ /LO ₂ 2) Swirl coax: 20% ox pressure drop 3) Shear coax: 33% ox pressure drop 4) Swirl coax: 60% ox pressure drop	Obtain steady-state and dynamic characteristics

(continued)

Table 1 Summary of information from reviewed projects, research tasks, and investigations (Continued)

Throttling methodology	Program	Program period	Organizations	Engine/rocket designations	Operating parameters	Throttling	Propellant combinations/injector type	Throttling related research focus
Gas injection	Advanced Throttling Concepts Study	1964	1) Pratt and Whitney Aircraft 2) Air Force	Research engine	1) 15,000 lb rated thrust, 300 psia rated p_c , 1.7 MR 2) Cross-injection combustion gas	2–100%	A-50/N ₂ O ₄	Evaluate injector systems that provide high combustion performance during deep throttling
Gas injection	Throttling Concept Study	1965	1) Bendix Corporation	Research engine	1) 14 lb rated thrust, 105 psia rated p_c 2) Nitrogen gas	35-to-1	A-50/N ₂ O ₄	Evaluate gas injection technique
Multiple chambers	Advanced Thrust Chamber for Space Maneuvering Propulsion Program	1965, 1967	1) Rocketdyne 2) Air Force Rocket Propulsion Lab.	Research engine	1) 30,000 lb + 3000 lb rated thrust 2) 2 chambers	9-to-1	LH ₂ /LF ₂	Investigate an advanced space maneuvering propulsion system
Multiple chambers	N/A	1976–1986, 1981–1993	Glushko	RD-170/RD-171	1) 1,777,000 lb rated thrust 2) 4 chambers	56–100%	RP-1/LO ₂	Russian engine used on Energia and Zenit vehicles
Multiple chambers	N/A	1992–1999	Glushko	RD-180	1) 933,400 lb rated thrust 2) 2 chambers	40–100%	RP-1/LO ₂	Russian engine used on Atlas III and Atlas V
Pulse modulation	Lunar Flying Vehicle Study	1964	1) Bell Aerospace Company 2) NASA Marshall Space Flight Center	Bell model 8414 throttleable maneuvering engine	100 lb rated thrust, 80 psia rated p_c	1–12–100%	1) A-50/N ₂ O ₄ 2) Triplet FOF	Engine development for use in Lunar Flying Vehicle Application
Throat throttling	Reaction Motors, Inc. Study	1947	1) Reaction Motors, Inc. 2) U.S. Navy	Research engine	2000 lb rated thrust, 315 psia rated p_c	1) 6.25-to-1 ^a 2) 60, 75%	Aniline/acid	Design and develop a variable thrust LRE
Throat throttling	MIT Naval Supersonic Lab. Study	1961	1) MIT Naval Supersonic Lab. 2) U.S. Navy	Research engine	1) 1800 lb rated thrust, 300 psia rated p_c	1) N/A	1) Air	1) Investigate throttling by gas injection into the nozzle throat
Variable area injector	Variable Thrust Engine Development Program ^a	1950	Reaction Motors, Inc.	Research engine	5000 lb rated thrust ^a	50-to-1 ^a	1) Hypergolic with WFNA/WFNA ^a 2) Pintle-type injectors ^a	Rocket engine development to meet the demand for more flexibility by continuously variable thrust
Variable area injector	Project MX-794	1951	1) Willow Run Research Center Univ. of Michigan 2) USAF	Engine 0151	1) 200 lb rated thrust, 300 psia rated p_c , 2.75 MR 2) 600 lb rated thrust, 300 psia rated p_c 3) 3000 lb rated thrust, 300 psia rated p_c	1) 7.5–205% 2) 35-to-1 3) 18-to-1 4) 6-to-1	1) 80% aniline and 20% furfuryl/RFNA-6.5% NO ₂ 2) NH ₃ /RFNA-20% NO ₂ 3) J-P3 (lead with furfuryl alcohol)/WFNA (with max. 2% H ₂ O) 4) J-P4 (lead with furfuryl alcohol)/WFNA (with max. 2% H ₂ O) 5) Swirl, annular orifice, multiport swirl injectors	Evaluate for missile use

(continued)

Table 1 Summary of information from reviewed projects, research tasks, and investigations (Continued)

Throttling methodology	Program	Program period	Organizations	Engine/rocket designations	Operating parameters	Throttling	Propellant combinations/injector type	Throttling related research focus
Variable area injector	NACA Study	1955	NACA Lewis Flight Propulsion Lab.	Research engine	1) 1000 lb rated thrust, 300 psia rated p_c	1) 9.6–171% 2) 8.6–159%	1) Liquid NH ₃ (with lithium)/liquid MON-29 2) Triplet impinging-jet and swirl cup injector	Investigate variable thrust methodology
Variable area injector	Lunar Module Descent Engine Program	1963–1967	1) TRW Inc. 2) NASA	Apollo LMDE	9850 lb rated thrust, 106 psia rated p_c	10–100%	1) A-50/N ₂ O ₄ 2) Pintle injector	Develop and man-rate a LMDE
Variable area injector	TRW, Inc. Study	1965, 1968	1) TRW Inc. 2) NASA	MIRA 150A	150 lb rated thrust, 108 psia rated p_c , 1.59 MR	18–122%	1) MMH/MON-10 2) A-50/N ₂ O ₄ 3) Coaxial pintle injector	Design for use as an attitude control engine on the Surveyor spacecraft
Variable area injector	Gaseous Propellant Throttling Rocket Engine Study	1965–1968	AFIT	Research engine	1) 100 lb rated thrust, 350 psia rated p_c , 2.0 MR 2) 70 lb rated thrust, 230 psia rated p_c 3) 75 lb rated thrust, 2.0 MR 4) 76 lb rated thrust	1) 4.1-to-1 2) 7-to-1 3) 5-to-1	GH ₂ /GOX	Research experiments using gaseous propellants on thrust variation
Variable area injector	LSAM design	2005–current	1) NGST 2) NASA	TR202	8700 lb rated thrust, 700 psia rated p_c , 6.0 MR ^a	1) 5.3-to-1 ^a 2) Injector and chamber tested 10-to-1	1) LH ₂ /LO ₂ ^a 2) GH ₂ /LO ₂ tested	Engine design to meet LSAM requirements
Hydrodynamically dissipative injector	Demonstration of throttleable LO ₂ /H ₂ injection concepts	2001	1) Pennsylvania State Univ. 2) NASA Marshall Space Flight Center	Research engine	1000 psia rated p_c , 6.0 MR	1) 10-to-1 2) 4.83 < MR < 7.21	1) GH ₂ /LO ₂ 2) Russian swirl injector	Conduct hot-fire experiments of a designed swirl injector across the throttleable range

^aDesign only.

A. High-Pressure-Drop Injectors

A typical LRE with a single, fixed-geometry injector can generally be throttled approximately 2-to-1 or 3-to-1 [6,19]. To accommodate deep throttling requirements, often 5-to-1 or more, with a fixed-geometry injector, higher-than-usual injector pressure drops or head losses are necessary to maintain a minimum injector pressure drop at minimum thrust. A satisfactory minimum injector pressure drop is required to ensure adequate resistance for system stability and to ensure sufficient mixing and atomization for good performance. In general, experience and analysis have shown that the nominal hydraulic pressure drop ratio ($\Delta p_{inj}/p_c$), occasionally referred to as *stiffness* or *hardness ratio*, should be around 15–20% to avoid combustion instability, but can range from 5 to 25% depending on injector type and thermodynamic conditions [19,24].

The primary advantage of the fixed-geometry injector is simplicity. The flow of propellants can be regulated by control valves in the propellant lines. Propellants can also be regulated using variable area cavitating venturis [25,26]. Because injector hydraulic pressure drop ratio varies linearly with flow rate for liquid propellants, however, a 5% minimum $\Delta p_{inj}/p_c$ at 10% thrust would require 50% $\Delta p_{inj}/p_c$ at 100% thrust. Thus, the primary disadvantage of a high-pressure-drop injector is the high supply pressure requirement imposed on the pressurization system and tankage (for pressure-fed propellant supply systems) or turbomachinery (for pump-fed systems) [19].

1. Project Thumper (1948) [27]

Project Thumper, a program in the United States to develop high-altitude antiaircraft ballistic missile defense against the German V-2 rockets, investigated early rocket engine throttling, including instabilities during throttling operation, throttling engine performance, and the limits of rocket engine throttling [28]. A low-pressure-drop injector and several iterations of high-pressure-drop showerhead injectors were evaluated. Initial tests with the low-pressure-drop injector showed externally observed oscillations between 10 Hz and 20 Hz, called motorboating, at low thrust conditions. These oscillations were eliminated with a high-pressure-drop injector; this injector was thought to have eliminated liquid oxygen boiling in the manifold, damping pressure perturbations in the chamber by increasing the resistance of the injector, and/or decreasing combustion transients at the injector face. Erratic irregular fluctuations, called chugging, were encountered during testing below 65 psia chamber pressure. The chugging was described as resembling an engine operating intermittently, such as an explosion-cycle thrust chamber, and was attributed to pressure oscillations causing intermittent oxygen vaporization in the injection orifice. A transition from smooth combustion to motorboating and then chugging was observed as chamber pressure continued to decrease. A high frequency instability between 1100 Hz and 1500 Hz, called whistling, was present in most of the tests with the high-pressure-drop injector.

The performance over the throttling range generally agreed with theoretical model trends. The characteristic velocity efficiency is shown in Fig. 1. A significant reduction in performance, however, occurred at less than roughly 30% chamber pressure. Higher than expected propellant flow was observed to be necessary at low thrust and was thought to be due to poorer combustion at lower chamber pressures. Conditions 1 through 6 plotted in Fig. 1 examined the effects of nozzle area expansion, chamber length, throat diameter, and injector modifications on the performance. However the key finding was the significant drop in performance at the lower power levels.

Heat transfer rates were found to remain constant over most of the throttling range down to roughly 59% chamber pressure. Below this, the heat transfer rate dropped off and was assumed to be due to separating flow in the nozzle. At 56% chamber pressure using the low-pressure-drop injector and at 87% chamber pressure using the high-pressure-drop injector, the heat transfer rates increased 2.5–3 times over normal, which was correlated to a 300 Hz oscillation in the external environment, but it was not understood whether this was a

cause or a symptom of the high heat transfer. Below roughly 30% chamber pressure, fuel coolant was expected to vaporize in the regeneratively cooled engines. To prevent vaporization of the coolant, the engine was required to operate with a low mixture ratio. This helped prevent roughness, burnout, or cessation of operation due to fuel vaporization in the coolant jacket.

2. Project MX-794 (1950) [21]

Under contract to the United States Air Force, the Willow Run Research Center at the Univ. of Michigan measured rocket engine throttling performance to analyze and design ballistic and airborne defense systems. Several instabilities were encountered during testing at lower chamber pressures. These were described as whistling, howling, rough burning, and chugging as the thrust was reduced. During whistling and howling, the noise intensity was high enough to shatter glassware, and standing wave patterns were visible in water on the test cell floor. Whistling was likely the acoustic response from a high frequency combustion instability. Howling and rough burning were likely sounds generated from low frequency combustion instability, or chug in current nomenclature. Chugging was described as an instability with pulsing combustion at the time, and was probably a low frequency hydraulic instability in the injector. Heat transfer in the engine rose abruptly during the combustion instabilities. Performance was observed to decrease during throttling. Hysteresis was observed during attempts to move in and out of the regions of instability.

One conclusion of this program was that unstable combustion was a serious problem in throttling and could result in erratic operation and destruction of the rocket engine. It was also concluded that a variable area injector would probably be required to successfully throttle over a range of 5-to-1, and that it would be feasible to use regenerative cooling over the full 10-to-1 throttling range.

Several throttling methodologies were also analyzed in these studies. A table comparing these methods is shown in Fig. 2. Variable area injectors, described in a later section of this paper, were identified to be the most promising throttling method.

3. NASA Lewis Research Center Study: Modified RL10A-1 (1964) [29]

A modified RL10A-1 engine was used to investigate steady-state and dynamic characteristics during throttling from 100 to 10% of thrust in an altitude facility at the NASA Lewis Research Center. The modifications to the standard regeneratively cooled and pump-fed RL10A-1 engine included the addition of a turbine bypass valve to vary the amount of flow through the turbine, smaller oxygen injector orifice areas to increase injector pressure drop and provide better atomization at low thrust, and a chlorotrifluoroethylene monomer insulation between the oxygen and hydrogen injector manifolds to reduce heat transfer that caused oxygen boiling at low thrust. Analysis indicated that rapid transients from high to low thrust could

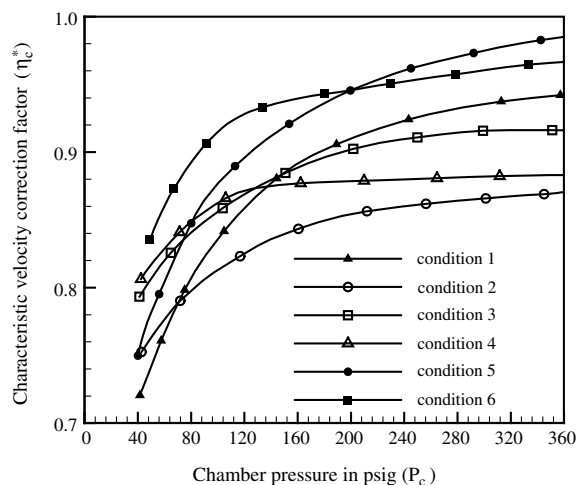

Fig. 1 Characteristic velocity efficiency from Project Thumper [27].

No.	Method of Throttling	Primary Variables	Supply Pressure P_s	Chamber Pressure		Pressure Drops				Area Ratio		Throttling Range	Comments
				P_c	P_{c2}	Injector		Gov. Valve		Injector A_{i1}/A_{i2}	Gov. Valve A_{g1}/A_{g2}		
						ΔP_{i1}	ΔP_{i2}	ΔP_{g1}	ΔP_{g2}				
1		A_g	2235	60	600	15	1500	2160	135	1	1/40	1/10	Excessive supply pressure. For throttling range greater than 1/2.3.
			1000	260	600	65	350	675	50	1	1/8.5	1/2.3	
2		A_i	780	60	600	720	180	-	-	1/20	1	1/10	Single proportional control function and satisfactory supply pressure.
			1000	46	600	954	400	-	-	1/20	1	1/13.0	
3		A_g	797	60	600	15	150	722	47	1/3.16	1/40	1/10	Two control functions. Satisfactory supply pressure. Large throttling range possible.
			1000	30	600	7.5	150	962.5	250	1/4.57	1/40	1/20	
4		On-off Valve	750	60	-	690	-	-	-	1/21.4	1	1/10	Satisfactory for step throttling only.
			-	-	600	-	150	-	-	1	1		
5		A_i	750	600	600	150	150	-	-	1/10	1	1/10	Two control functions. 1/10 throttling possible with chamber pressure less than 600 PSIA.
			375	300	300	75	75	-	-	1/20	1	1/20	
6		A_g	15,610	600	600	150	15,000	14,860	10	1	1/385	1/10	Two control functions. Excessive supply pressure and governor valve area ratio for 1/10 throttling range.
			1000	600	600	150	350	250	50	1	1/3.42	1/1.53	
7		A_n	750	600	30	150	720	-	-	1	1	1/2.19	Throttling range insensitive to supply pressure. Not recommended as throttling method.
			750	600	60	150	690	-	-	1	1	1/2.14	
			1000	800	30	200	970	-	-	1	1	1/2.19	
			∞	∞	60	∞	∞	-	-	1	1	1/2.24	
			603	600	303	3	300	-	-	1	1	1/10	

ASSUMPTIONS MADE FOR CALCULATIONS:

1. Injector pressure drop (ΔP_i) must be at least 25% of chamber pressure (P_c).
2. Maximum practical governor valve area ratio A_{g1}/A_{g2} is 1:40.

3. Maximum injector valve area ratio A_{i1}/A_{i2} is 1:20
4. Characteristic velocity and thrust coefficients are constant over throttling range.
5. Maximum practical chamber pressure is 600 PSIA

* SUBSCRIPTS: 1 - Low thrust operation.
2 - High thrust operation.

PRESSURES: Pounds per Square Inch Absolute - PSIA.

Fig. 2 Chart of throttling techniques from Project MX-794 [21].

stall the fuel pump. Emphasis was placed on determining the steady and dynamic characteristics as well as the operational limitations due to interacting engine components.

Three injector configurations were tested, including a shear coax element injector with midlevel oxidizer pressure drop (33% chamber pressure), and two swirl coax element injectors with low (20%) and high (60%) oxidizer pressure drops. All three injector configurations included the injector manifold insulation as well as a transpiration cooled faceplate using approximately 2% of the total fuel.

Chug at about 170 Hz was evident at low thrust for all three injectors. The onset of chug, however, occurred at the lowest chamber pressures with the higher pressure drop injectors, as shown in Fig. 3, although mixture ratio played a significant role. At a mixture ratio of 4.5, for example, the onset of chug occurred at 32% thrust for the lowest pressure drop injector, and 25% for the middle-pressure-drop injector, and never occurred for the highest pressure drop injector.

Chug was defined for the purposes of Fig. 3 to be any noticeable periodic oscillation greater than the noise floor. The highest amplitude peak-to-peak oscillations of about 80% of chamber pressure occurred at the lower thrust-lower mixture ratio region. Figure 3 also shows that two of the injectors became stable again at chamber pressures less than about 40 psia or around 10% thrust. This restabilization at very low throttling is due to gasification of the oxygen, probably due to heat transfer from the warm hydrogen, at a rate sufficient to increase the oxygen pressure drop.

Figure 4 compares oxygen flow rate and pressure drop for the shear coax injector. The deviation from the linear pressure drop relation in the figure indicates a change in oxygen density, and the beginning of two-phase flow through the oxidizer injector orifices. The amount of deviation is shown in Fig. 4 to be dependent on the

temperature of the hydrogen fuel. The added injector resistance (increase in pressure drop) was enough to overcome the negative effects on stability of the increased compliance (more vapor) in the manifold. Several other methods to increase the oxidizer injector pressure drop were also proposed, including further reduction of the oxidizer injector area if pump head rise was available, providing heat to increase the amount of vapor in the manifold, and injecting gas into the liquid oxidizer manifold.

The engine was also operated in pressurized mode without the pump. Chamber pressures of 10 to 15 psia (about 3-5% rated chamber pressure) were explored over mixture ratios from 2 to 6. The lower limit of 10 psia was due to the inability of the exhaust nozzle to flow full at the available pressure ratio provided by the test facility. High temperatures were reached in the jacket outlet temperature at mixture ratios of 5 and higher. A temperature of 700°R at a mixture ratio of 5 was determined to be the safe limit since discoloration, metal erosion, and tube burnouts occurred at higher mixture ratios. These tests demonstrated the feasibility of reaching 3% thrust using pressure-fed propellants and inoperative pumps.

Reducing the chamber pressure from 100 to 33% reduced the specific impulse by about 3%, but the performance decay was faster below 33% chamber pressure. This influence was expected, because for fixed-orifice-injectors the liquid oxygen pressure drop is reduced with the square of the propellant flow rate, and probably worsened atomization and mixing. Performance was also worsened with the onset of chug, which reduced performance by an additional 8%. The high-pressure-drop swirl coax injector performed the best at low thrust compared with the other two injectors. Both swirl injectors also performed better than the shear element injector.

At a mixture ratio of 5, the chamber coolant jacket outlet temperature increased 100°R over the throttling range from 100 to

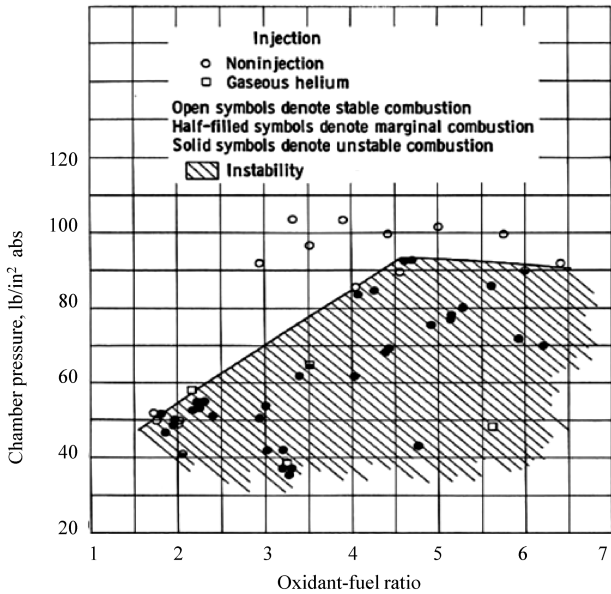

a) Low-pressure-drop injector

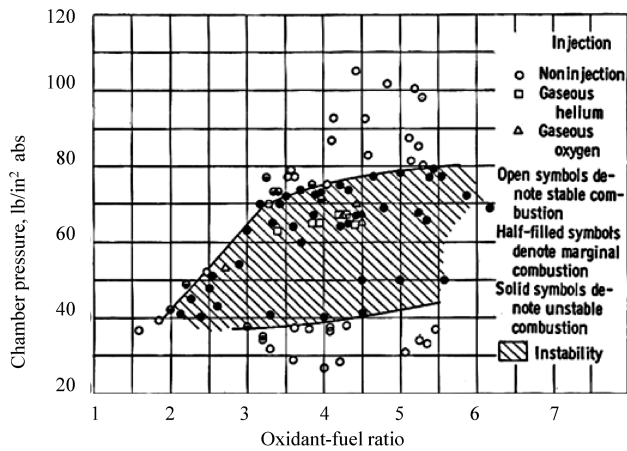

b) Middle-pressure-drop injector

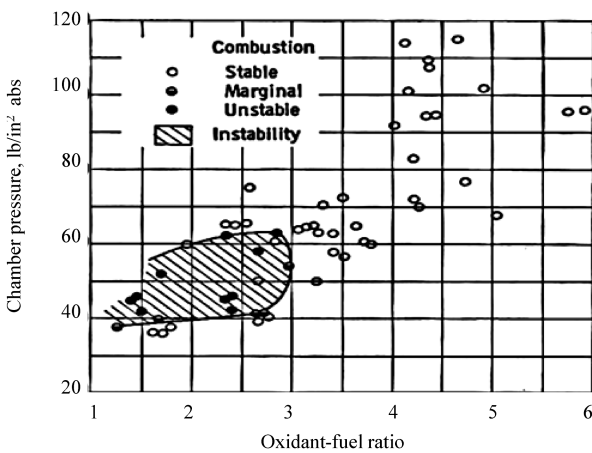

c) High-pressure-drop injector

Fig. 3 Chug stability limits of three injector configurations [29].

25%. The increase in temperature was due to the proportionate decrease in propellant flow rate (and coolant flow rate) with pressure. Overall, cooling ability decreased at lower thrusts, although adequate cooling was available over the range tested.

In addition to chug, a flow instability between 1 and 5 Hz occurred in the fuel system below chamber pressures of 33% thrust, or when the coolant jacket pressure reached the hydrogen critical pressure. Regions of mild oscillations and severe oscillations were

evident. The mild oscillations were 10–20% of the fuel weight flow. The severe oscillations at high mixture ratios required engine abort because of overheating of the coolant tubes. It was shown that pump boundary conditions and effects were not a cause by demonstrating the phenomenon in engine pressurized mode operating without the pump. The speculation was that an unstable liquid-vapor interface was established in the chamber coolant channels. The theory was verified when gas helium or hydrogen was injected upstream of the coolant jacket, which created a finely distributed region of phase transition. Gas weight flows of 20% of the hydrogen weight flow were needed for stabilization. Another method for avoiding the oscillation was to operate at lower mixture ratios.

Dynamic characteristics were investigated during thrust transients. At high deceleration ramp transients, the pump was driven into a stall condition. This high deceleration ramp created a fuel flow excursion from normal flow rates into the stall region. The flow excursion, as simulated with an analytic system model, showed that the accumulator action of the chamber cooling jacket and feed line maintained a high pump discharge pressure while the head-rise potential of the pump decayed rapidly during the transient. No operational problems occurred with high acceleration ramp transients.

4. ARES Throttling: Scaling Design Study Program (1967) [30–33]

The Air Force Rocket Propulsion Laboratory at Edwards Air Force Base sponsored development of a throttleable and restartable staged-combustion cycle engine called the advanced rocket engine storable (ARES) engine at the Aerojet General Corporation. The design goal was 10-to-1 throttling using a high performance throttling injector (HIPERTHIN) [34] and a transpiration cooled chamber. Although no testing was performed, details of the design changes from a fixed thrust engine to a throttleable version are provided in the documentation along with predictions of stability and performance.

Aerojet Liquid Rocket Company also studied a throttling injector concept applicable to an advanced cryogenic engine and suitable for staged combustion engines. The engine system was to be throttleable over a 33-to-1 thrust range. The unique injector design contained an integral heat exchanger to extend throttling by gasifying the cryogenic propellants before injection. The heat exchanger operated by tapping off combustion gases which were directed through a HIPERTHIN injector in a counterflow manner. Predicting the pressure drop aspects of this injection system was difficult because the propellant phase in the injector transitioned from supercritical, to two-phase, to gas as the engine throttled down. With gas injection, the injector maintains a constant $\Delta p_{inj}/p_c$ over a wide range of throttling, which is advantageous to an engine system because adequate feed system impedance can be maintained without using excessive injection pressure drops at full thrust. Testing of the heat exchanger showed nonuniform heat exchange surface in the injector manifold area and insufficient surface area.

5. DC-X and DC-XA (1991) [35]

The regeneratively cooled expander-cycle RL10A-5 engine, a sea-level throttleable derivative of the RL10 engine family, was developed by Pratt and Whitney under contract to McDonnell Douglas through a Ballistic Missile Defense Organization funded program, for use on the DC-X (Delta Clipper-Experimental) vehicle, a single-stage to orbit rocket technology demonstrator. Four RL10A-5 engines were installed on the DC-X vehicle. The three major differences of the RL10A-5 engine from the rest of the RL10 engine family were sea level operation, throttle capability from 100% to 30% of rated thrust, and reusability. NASA later sponsored a continuation of the program called DC-XA (Delta Clipper: Experimental Advanced), which used the same engines.

Several successful flights of the DC-X and DC-XA included vertical launch, hovering, translating, and vertical landing. One flight reached an altitude of 10,500 ft. On the third flight, two of the engines started slower than the others and resulted in an uneven engine acceleration, but the engines recovered and performed nominally thereafter. The problem was traced back to gaseous helium

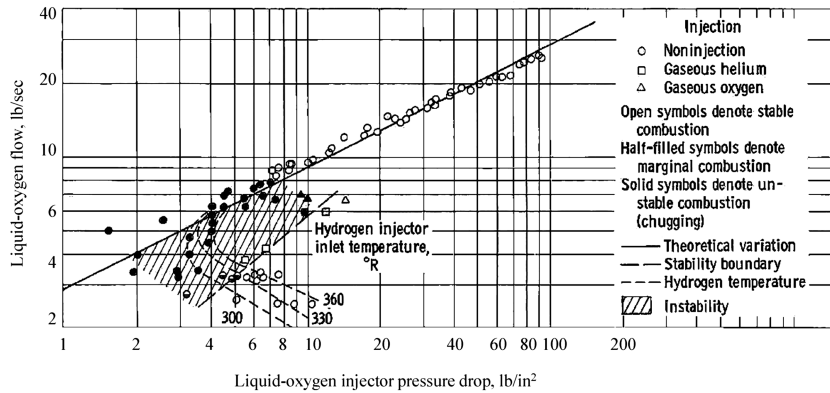

Fig. 4 Hydraulic characteristics with throttling of a liquid oxygen shear coaxial injector [29].

unwillingly being ingested into the liquid oxygen feed lines, degrading combustion, and lowering thrust. The RL10A-5 demonstrated a 3.3:1 throttling range.

6. NASA-Aerojet Joint Cooperative Study: RD-0120 (1996) [36]

Under a joint cooperative agreement with the NASA Marshall Space Flight Center (MSFC), the Aerojet Liquid Rocket Company in 1996 demonstrated off-nominal power operation of the staged combustion cycle RD-0120 engine for reusable launch vehicle (RLV) evaluations of the X-33 demonstrator vehicle propulsion system. Rated power levels between 25 and 100% were examined, including one test simulating an RLV abort scenario with continuous operation at 25% power level of 480 s duration. No combustion instability was observed at any power level. Following the long duration test at 25% power level, however, about 20% of the nozzle brackets which held the stiffening rings to the nozzle were found to be damaged; this was attributed to excessive nozzle vibration during separated nozzle flow at the sea level facility. The nozzle was not designed for operation at 25% power level, and could easily be redesigned to eliminate damage.

7. NASA-Boeing Rocketdyne Joint Cooperative Study: SSME (1997) [37,38]

Under a joint cooperative agreement with the NASA MSFC in 1997, Boeing Rocketdyne demonstrated off-nominal power operation of the staged combustion cycle space shuttle main engine (SSME) for RLV evaluations of the X-33 demonstrator vehicle propulsion system. The SSME does not have a higher-than-usual pressure drop; but it is classified in this section because at low thrust it maintains a high enough pressure drop to operate. Rated power levels of 17, 22, 27, 40, 45, and 50% were examined. Normal operation of the SSME ranges from 65 to 109% rated power level. Chamber pressure profiles from two tests are shown in Fig. 5. The SSME was recently throttled again in 2008 at the NASA Stennis Space Center.

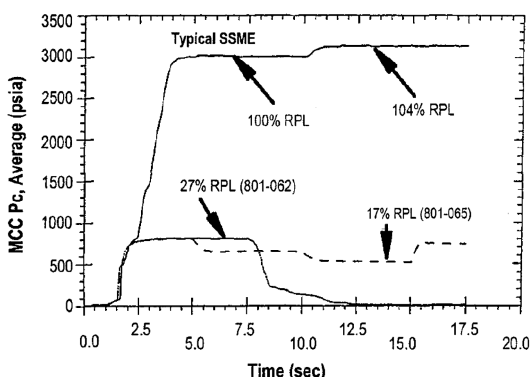

Fig. 5 SSME low power level chamber pressure [37,38].

Thrust was predominantly controlled using the oxidizer preburner oxidizer valve, and mixture ratio was controlled using the fuel preburner oxidizer valve. At low thrust, the chamber coolant valve (CCV) was closed more than normal to help increase turbine inlet temperatures, due to a concern about production of ice in the oxygen preburner. In fact, higher-than-expected nozzle separation heat loads in combination with the CCV modification precluded icing concerns. The mixture ratio was fixed between 3 and 4 to provide a safe margin from the high-pressure fuel turbopump boilout point (or stall), which also provided additional cooling of the main combustion chamber at low thrust. The stall point was the most significant issue that drove the operating point balance.

Reduction of the thrust to 17% (or about 6.4:1 throttling from maximum power level) was achieved by further closing of the fuel preburner oxidizer valve, since the oxidizer preburner oxidizer valve was already at a minimum area. High sample rate instrumentation did not include a chamber pressure measurement, but there was no evidence of combustion instability in accelerometer measurements. The oxidizer injector pressure drop was so small that the measurements from the test data were not valid, but the pressure drops across the control valves were high and possibly protected against chug. A pump flow test program was recommended to establish safe operating regimes for the pumps at thrusts lower than 17%.

There were many pump-related concerns before running the throttling tests, including rotordynamic stability of the turbopumps, running the high-pressure turbopumps at shaft critical speeds, the ability of the high-pressure fuel turbopump thrust bearing to lift off, the ability of the hydrostatic bearing of the high-pressure oxidizer turbopump to run in the stall region, the possibility of the freezing in the high-pressure turbopump turbines, the ability to sustain a satisfactory axial thrust balance, the bistability of the high-pressure oxidizer turbopump boost pump, and the performance of the turbopumps at low flow-to-speed ratios. Of these concerns, only a slight preburner boost pump bistability was observed at 50% rated power level.

8. Deep Throttling Common Extensible Cryogenic Engine (2005) [39-41]

Pratt and Whitney Rocketdyne conducted tests of a modified RL10 engine, assembled from a mixture of heritage development hardware and renamed the common extensible cryogenic engine (CECE) demonstrator. The engine was designed for technology development and risk reduction applicable to a deep throttling cryogenic lunar descent engine. Figure 6 shows the engine at multiple power levels during a hot run.

Two major hardware modifications to the RL10 engine system were made for CECE. First, features of the injector were altered to allow adequate operation over the full throttling regime. This included a reduction in the area of the oxidizer flowpath and a reduction of the outer row mixture ratio. These changes allowed full operation over the throttling range and improved thermal margin. The fuelside flow area was similar to the base RL10 engine and

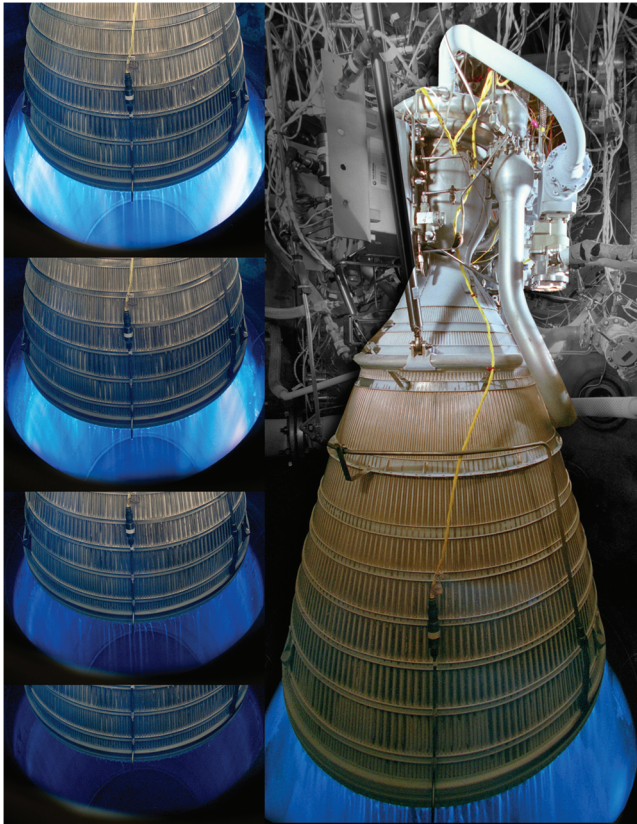

Fig. 6 CECE shown at multiple power levels [41].

needed little modification. The second modification was the selection of a valve suite that provided the necessary system control flexibility. The valve suite used in CECE is discussed in more detail in [39,40]; two key additions were a fuel turbine bypass flow to supplement the existing bypass flow route and the addition of a variable area cavitating venturi.

Over the Demo. 1.0, Demo. 1.5, Demo. 1.6, and Demo. 1.7 test series, CECE has accumulated 7435 s of total run time while achieving a throttle range in excess of 17.6-to-1. Figure 7 shows CECE at 30% power level with ice formation on the nozzle rim due to the cooling and eventual freezing of the steam by the cryogenically cooled nozzle wall. Swirl injector throttling, like that used by the RL10 and CECE throttling configuration, including effects of reduced mass flow rate and elevated chamber backpressure was studied in [42].

Chug oscillations, similar to those observed in [29,43], were encountered at low throttle power levels. The presence of vapor in the oxidizer manifold and feed system was deduced by extensive



Fig. 7 CECE at 30% power levels showing ice formation [39,40].

stability modeling to be responsible for the less than expected margin. An injector revision that incorporated insulation in the LO_2 manifold, similar to the injector revision described in [29], was tested in Demo. 1.6 and Demo. 1.7. The insulation provided additional chug margin by effectively decreasing the onset of chug to a lower power level. Using gaseous helium injection, as in [29], was also considered. The gas injection was successful in eliminating chug oscillations.

B. Dual-Manifold Injectors

A dual-manifold injector, also called two-stage, dual-element, dual-circuit, or dual-orifice, is an injector designed to maintain satisfactory injector pressure drops at low thrust levels while not requiring the often excessive pressure drops at full thrust seen in the high-pressure-drop injectors described in the previous section. The dual-manifold injector essentially combines two fixed-area injectors into a common structure, with independent feed systems controlling flow to each injector manifold. Deep throttling is achieved by proceeding from two-manifold (primary and secondary) operation at high thrust to single-manifold (primary) operation at low thrust, thus changing the effective injection area. Changing from two-manifold to single-manifold operation is usually as simple as closing a valve. Several constraints must be optimized in the injector design from system requirements, including the pressure drop at the minimum power point, the minimum pressure drop for the secondary manifold, and the maximum injector pressure at full power (maximum thrust). This injection method has been used for fuel injection in turbojet engines, and it was also used by German engineers in the early days of throttling LRE development [19].

Higher pressure drop across the injector at low thrust is advantageous for both performance and stability, as previously described. Finer atomization of the propellants usually depends on higher injector pressure drop [44]. The injector hydraulic pressure drop ratio required to promote stable combustion is injector dependent, but generally should be at least 15–20% of the chamber pressure.

As with the high-pressure-drop injectors previously described, continuous throttling is provided by control valves in the propellant feed systems. At the operating point where the pressure drop in the secondary manifold reaches its minimum, the control valve feeding the secondary manifold closes, and all the flow transitions to the primary manifold. This abrupt reduction in injection area causes an abrupt increase in injector pressure drop across the primary manifold when flow rate is held constant. The transition historically has ranged between 20 and 50% of full flow. Studies have been performed to examine methods for transitioning smoothly by varying flow through both manifolds appropriately.

1. Advanced Throttling Concepts Study (1963) [45–47]

An Advanced Throttling Concept Study (1963–1965) was conducted by Pratt and Whitney Aircraft (P&WA) and United Technology Center and a parallel High Energy Advanced Throttling Concept Study (1964–1966) was conducted by P&WA under two separate Air Force contracts. Before these studies, P&WA sponsored tests of a dual-manifold subscale injector over a 23-to-1 flow range with the propellants that would be used in the Advanced Throttling Concept Study. This study also examined gas injection and combined methods of throttling and is discussed in other sections. The intent of the Advanced Throttling Concept Study was to evaluate injector systems to provide high combustion performance during deep throttling (specified down to 50-to-1). The engine was pressure-fed and used storable propellants. Two injector patterns were examined in this study; the triplet-element injector is shown in Fig. 8.

Each propellant orifice consisted of a primary flow inner orifice and a secondary flow concentric outer orifice, as illustrated in Fig. 9. A flow divider valve controlled the flow split between the primary and secondary flowpaths. High average injection velocities were maintained over a wide thrust range by the controllable flow split and by the momentum exchange between the two concentric streams, which was high enough to obtain good interpropellant mixing. The primary flow was found to accelerate the low secondary flow (even as

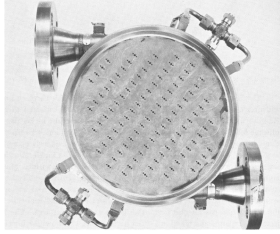

a) Hardware photo

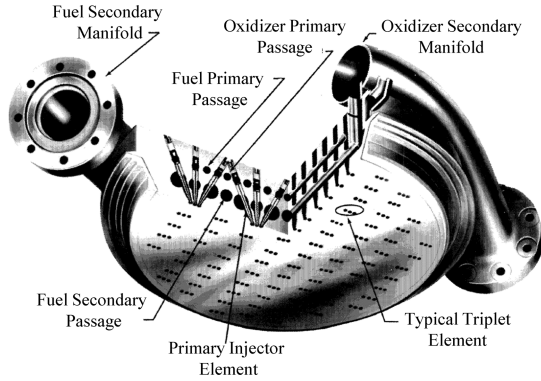

b) Schematic diagram

Fig. 8 Triplet-element dual-manifold injector [45–47].

low as 2% thrust), as was demonstrated in water flow experiments. Acoustic liners on the chamber walls were used to damp high frequency chamber pressure oscillations.

System analyses before the test found that the pressure inside the secondary oxidizer manifold would be below the propellant vapor pressure at low thrust. In the transition thrust range (with two-phase propellant) and pure vapor thrust range at low power levels, there would be significant change in the primary-to-secondary flow split, but only a small effect on total propellant flow, so the presence of vapor in the oxidizer secondary manifold was expected to have a negligible effect on mixture ratio and chamber pressure. A nonlinear dynamic system model also showed no divergent oscillations in the chamber at any point in the thrust range and was used to design optimum propellant supply line geometry. Performance and throttling characteristics of both the triplet-element injector and the second injector developed under this program (and not discussed here) are limited release data.

The intent of the High Energy Advanced Throttling Concept Study was to evaluate the throttling capability and performance of the dual-orifice injectors using high energy F_2/H_2 pump-fed propulsion systems for use in maneuvering satellite applications. Tests were performed with several subscale and full scale injectors with dual-

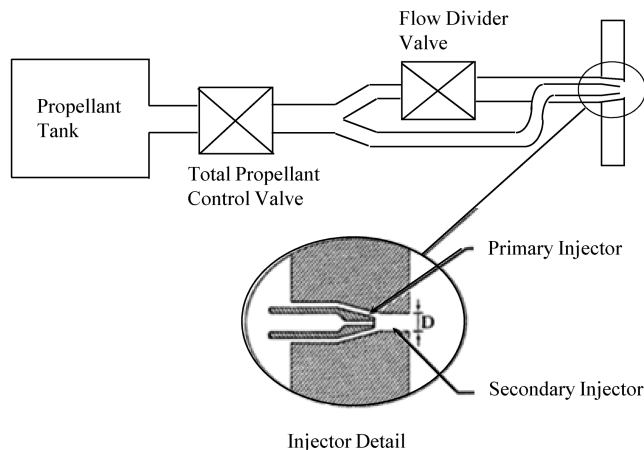
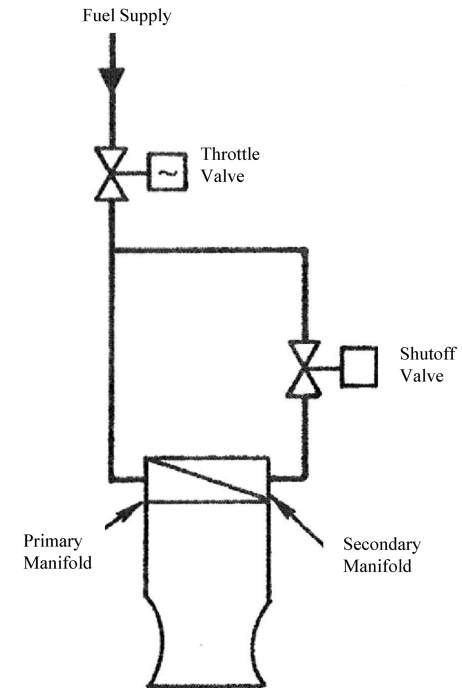

Fig. 9 Dual-manifold injection flow system schematic [45–47].

manifold concentric injector orifices and upstream flow control valves as in the Advanced Throttling Concept Study. The subscale injectors were throttled over a 12:1 thrust range. The full scale injectors were throttled over a 29:1 thrust range. Gaseous hydrogen was used as the fuel and thus only the oxidizer dual-manifold was needed.

2. Chamber Technology for Space Storable Propellants (1964) [48–51]

A 5 yr analytical and experimental program called Chamber Technology for Space Storable Propellants investigated dual-manifold injector throttling. The purpose of the program was to develop design criteria for selected space storable fuels in combination with oxygen difluoride. FLOX (70% fluorine, 30% oxygen) was experimentally verified as an excellent simulant for oxygen difluoride in terms of performance and heat transfer and was



a) Parallel scheme

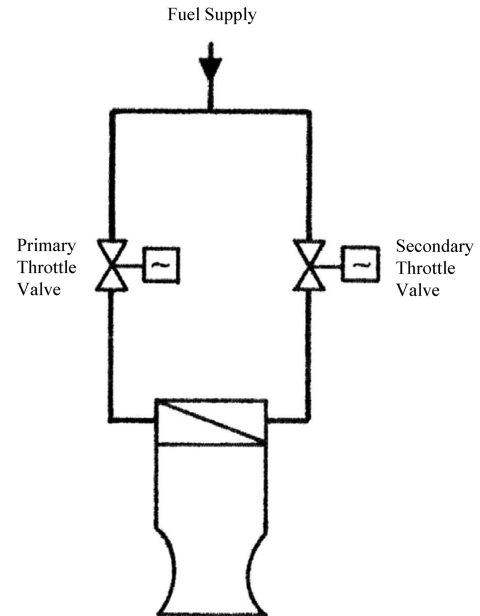

b) Series scheme

Fig. 10 Dual-manifold flow control schemes [48–51].

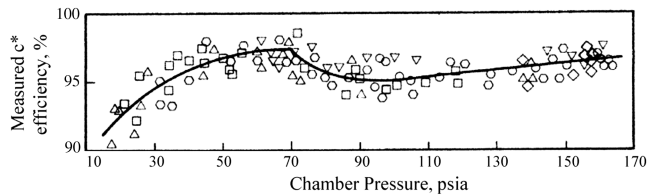

Fig. 11 Dual-manifold throttling performance with series valve configuration [50]; propellants: FLOX/MMH; mixture ratio: 1.79:2.36; chamber length (injector throat): 10.32 in.; test number: 2 ○, 3 □, 4 ◇, 5 △, 6 ○, 7 ▽.

substituted as an oxidizer in most tests because of its lower cost. The injector contained dual manifolds for both fuel and oxidizer. The transition to primary-only flow occurred at 49% thrust. The engine repeatedly throttled over a 10-to-1 range in a variety of duty cycles including demonstration of continuous throttling. The c^* efficiency ranged from 92 to 98% over the thrust range with peak values just below the transition point with the primary manifold operating only and at the highest thrust level with both manifolds operating together.

Two valve flow control schemes, parallel and series as shown in Fig. 10, were investigated. The parallel valve scheme allowed control of the flow to both the primary and secondary manifolds simultaneously. At the transition chamber pressure, the secondary flow was cut off and the single throttle valve fully opened. The difficulty with this simple parallel system was that four valves had to operate simultaneously to ensure a smooth thrust change at transition. The series valve scheme provided independent flow control to each manifold propellant line. Throttling began by reducing secondary flow with the primary valve still fully opened. Upon closure of the secondary valve, the primary flow was reduced to continue throttling. The series scheme provided a performance advantage at the midthrust range before throttling down through the predetermined chamber pressure.

One case of instability occurred with rough combustion at 90% thrust and 170 Hz and a peak-to-peak chamber pressure oscillation of 13%. This oscillation was eliminated upon closure of the secondary injector control valve. Release of trapped injector purge gases between the fuel throttle valve and injector probably triggered the instability by passing two-phase flow through the injection orifices. A change to the fuel injector purge pneumatic system was made for subsequent tests and no further instabilities were encountered. Otherwise, all thrust levels demonstrated excellent stability.

Peak performance occurred at secondary flow cutoff when there was a maximum injector pressure drop, or high injection velocity. The performance curve using the series valve configuration is shown in Fig. 11. Ingebo [52] relates volume mean droplet diameter, D_{30} , to jet diameter D and velocity V for impinging stream injectors.

An empirical correlation was then developed that related injector design parameters to the combustion efficiency. The relationship is Eq. (2)

$$\eta_{c^*} = 1 - A \left(\sqrt{\frac{D}{V}} \right)^B \quad (2)$$

where A and B are empirical constants whose values change for different propellant combinations and chamber geometries. The primary and secondary systems can be combined into a mass-weighted average c^* efficiency. No variation in the Rupe mixing efficiency E_m [53] was shown at any point in the entire throttle range.

The system response in general was good, although there was a significant delay when traversing from low thrust to high thrust because of the need to prime the secondary manifold. This would have to be corrected for fast thrust response missions. Continuously flowing fluid through the secondary manifold, either by a bleed flow through the secondary valve or a bleed flow from the primary fluid flow, was proposed to reduce the response during transition.

The throttling heat transfer results suggested that the boundary layer in the nozzle region would transition from turbulent to transitional and/or laminar at some point during the throttling range.

3. Reusable Rocket Engine Program (1967) [54–65]

Pratt and Whitney contracted with the U. S. Air Force over several years in the late 1960s and early 1970s to develop a reusable advanced cryogenic staged combustion engine. The initial configuration of this engine was required to throttle 5-to-1 and deliver 96% theoretical specific impulse at nominal thrust and 94% during throttling. Consequently the injectors included dual-manifold systems in both oxidizer circuits of the preburner and main injectors, and a variable area system in the fuel circuit of the preburner injector. Both injectors used oxidizer tangential-entry swirl coaxial element designs with dual-inlets, with the main injector including two tangential inlets (also called a stacked configuration) and the preburner injector including one tangential inlet and one axial (not self-atomizing) inlet. Testing in component and staged combustion configurations revealed stable operation over the 5-to-1 range as well as dynamic stability demonstrated by combustion chamber pulse guns with up to 80 grains of explosive. Unfortunately, the use of both dual-manifold oxidizer and variable-geometry fuel systems in the preburner was found to be difficult to control, the variable area fuel circuit experienced mechanical problems, and the hot gas temperature profile variability exceeded requirements. The specific impulse efficiency of the main injector was about 93% at 100% power level, and about 90% at 20% power level, which also did not meet requirements. The c^* efficiencies were about 98 and 96% at nominal and throttled conditions.

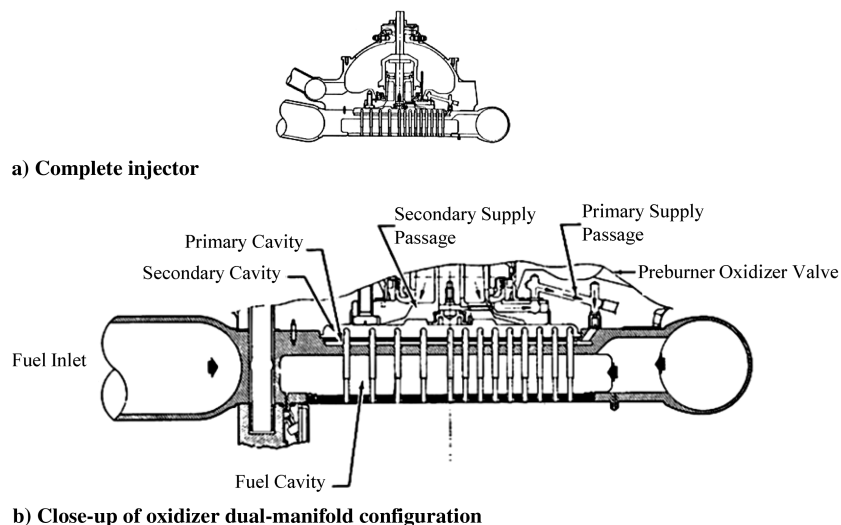

Fig. 12 XLR-129 dual-manifold preburner configuration [54–65].

A subsequent phase of this program, with an engine renamed the XLR-129, involved modification of the preburner and the main injector in an attempt to satisfy these requirements, including a modification for 99% c^* efficiency at rated thrust and 97% efficiency during throttling. The design for the main injector eliminated the dual-inlet (or stacked) oxidizer circuit and used one major flow passage. The design for the preburner eliminated the variable area fuel system in favor of a fixed fuel area, but modified the dual-manifold oxidizer circuit from one tangential inlet and one axial inlet to two tangential inlets. This preburner configuration is shown in Fig. 12, and the dual-inlet oxidizer swirl coaxial injector element is shown in Fig. 13. Extensive cold flow testing of dozens of preburner element design configurations was conducted to develop a hydrodynamically stable flow over the 5-to-1 operating range.

Initial testing of the preburner showed satisfactory hot gas temperature profile variability, but chug was encountered at 20% power level with amplitudes of about 11% of chamber pressure and frequencies between 75 and 150 Hz. Development analysis and testing indicated that the chug was caused by two factors: low secondary circuit LO_2 pressure drop and excessive secondary LO_2 manifold volume. Oxygen flowed through both oxidizer circuits over the entire throttling range, so that at low power levels, pressure drop in the secondary manifold was reduced to a few percent of chamber pressure. The chug was never eliminated, even by increasing the primary flow split to 90% and increasing the mass-weighted percent pressure drop to nearly 60%. It was suggested that preburner pressure oscillations were bypassing the high-pressure-drop primary flow and driving the system from the secondary flow. This did not happen during the initial phase of the program with a different inlet configuration, even with mass-weighted pressure drops to as low as 4% of chamber pressure. It was predicted that a reduction of the secondary manifold volume by 20–40% would stabilize the system, and during component development a redesigned injector with reduced LO_2 manifold volumes in both primary and secondary circuits operated without chug at the 20% power level, although during many tests there was leakage between the primary and secondary circuits.

4. Throttleable Primary Injector for Staged Combustion Engine Program (1968) [66]

Aerojet Liquid Rocket Company, under contract to the Air Force Rocket Propulsion Lab., demonstrated a throttleable main injector for a staged-combustion cycle, space engine using storable propellants and a platelet HIPERTHIN injector [34]. The engine was designed to operate over a 10-to-1 throttling range. Four injector configurations were tested, including three single-manifold injectors, showerhead oxidizer/showerhead fuel, showerhead oxidizer/impinging fuel, and impinging oxidizer/impinging fuel, and one dual-manifold injector with impinging oxidizer/impinging fuel. The dual-manifold injector consisted of two fuel manifolds and two oxidizer manifolds with independent platelet circuits for each manifold, as illustrated in Fig. 14.

To achieve the full 10-to-1 throttling range, the main injector included dual manifolds in both fuel and oxidizer circuits, although only a single manifold would be used at low thrust for fuel and oxidizer. The lowest throttling points were stable when single manifolds were used for both fuel and oxidizer. Chug with peak-to-peak amplitudes of 44% of chamber pressure at 54–115 Hz occurred when the dual manifold was used with one propellant, although dual manifolds at low thrust was not the normal configuration. Perform-

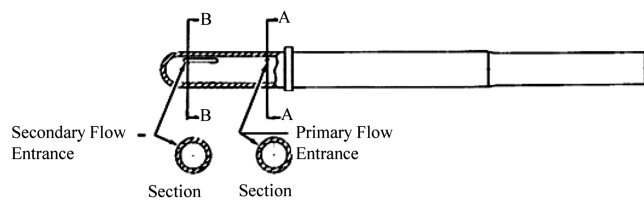

Fig. 13 XLR-129 dual-inlet swirl coax oxidizer element [54–65].

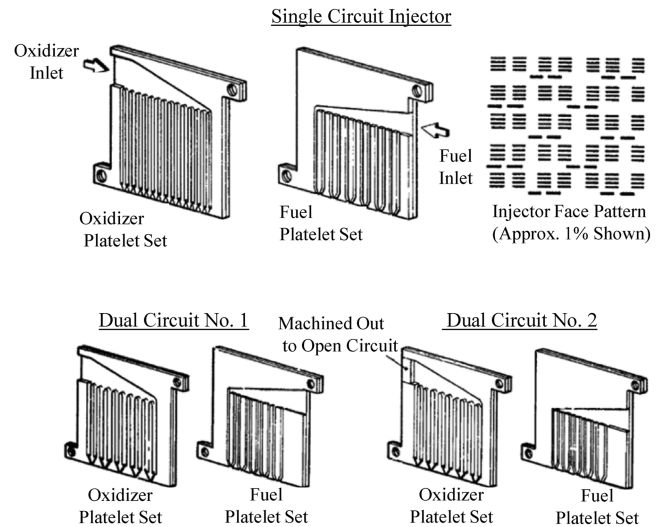

Fig. 14 HIPERTHIN platelet dual-manifold injector design [66].

mance of the dual-manifold injector was favorable, showing as good as or better than the single-manifold designs at the tested mixture ratios, due to the increased atomization of the higher velocity elements producing more momentum exchange at the higher pressure drops.

5. Advanced Expander Test Bed Program (1990) [67–73]

Pratt and Whitney was contracted by NASA to develop and demonstrate the advanced expander test bed (AETB), an expander-cycle oxygen–hydrogen engine technology applicable for space engines. Among many other features, the AETB was to have a high degree of throttleability with a requirement of 5-to-1 and a goal of 20-to-1. Design of the dual-manifold injector had been completed previously in an inhouse Pratt and Whitney Space Engine Component Technology Program. Only the oxygen circuit used a dual manifold; the fuel flowed through a single manifold. The two oxygen streams mixed within the injector element. A lumped parameter electrical circuit analogy analysis of the feed system predicted no chug at 5, 10, and 20% thrust. Part of the AETB program evolved into a separate technology development NASA Space Act Agreement. This program involved testing a 25 Klbf Thrust Chamber Assembly designed for 20-to-1 throttling capability using the same AETB dual-manifold injector design. Testing took place in 1996 at NASA Marshall Space Flight Center; the data are currently Pratt and Whitney Rocketdyne proprietary.

C. Gas Injection

Gas injection into propellant, also referred to as foamed-flow or propellant aeration, is a throttling methodology for LREs that reduces the bulk density of the propellants by introducing a much lower density (sometimes inert) fluid into the propellant flow. The change in flow rate is typically small. For liquid flows at constant flow rate, the pressure drop is inversely proportional to the bulk density. Thus, with gas injection at a particular thrust level, the liquid circuit injector pressure drop is increased. The higher pressure drop increases the chug stability margin thrust range and may increase the performance for fixed-geometry injectors. Russian experience suggests, however, that gas injection can lead to the onset of high frequency pressure fluctuations [4].

1. NACA Research (1956) [74]

A research memorandum published in 1957 by the NACA Lewis Flight Propulsion Lab. demonstrated rocket thrust variation with foamed storable propellants, using helium as the foaming gas. Several qualitative tests of the gas injection device were made in water. The final helium injector device consisted of a 2 in. long tube with 11 circles of 20 small holes. Careful calibration of the device

was necessary to obtain smooth homogeneous injection and to prevent surges of gas into the liquid. For this system, helium pressure no more than 100 psi greater than the liquid pressure was allowed to obtain smooth helium injection.

A theoretical model was developed that calculated the reduction in liquid flow as a function of gas-to-liquid ratio. The model considered isothermal gas flow under thermal equilibrium and, separately, adiabatic flow assuming no energy exchange between the gas and liquid. Less gas injection was shown to be needed at a particular thrust level with a denser liquid-propellant flow. Gas injection for thrust variation was shown to be a feasible technique that did not impair combustion efficiency.

It was pointed out at the time of the program that there would be a weight penalty for the additional propellant and its associated hardware; also the discharge coefficients and heat transfer characteristics for a foamed fluid at various conditions would need to be characterized. The pressure difference between the liquid and gas would need to be kept low to produce homogenous, uniform, and stable foams. Water flow experiments showed that a large pressure difference created intermittent liquid flows, which could create low frequency combustion instability.

2. NASA Study: Modified RL10A-1 (1964) [29,43]

During throttling tests of a modified RL10A-1 at the NASA LeRC, described in a previous section, chug occurred at thrust levels higher than expected due to oxygen boiling in the manifold. The sources of the boiling were increased fuel temperatures in the adjacent manifold, along with reduced oxygen saturation temperatures. Videos were taken of the liquid oxygen manifold through a sapphire window. For a particular chug oscillation cycle, oxygen vapor bubbles were observed to form inside the liquid oxygen manifold and then collapse at the same frequency as the chamber oscillations. A sequence of events postulated for this coupled dynamic system was as follows: 1) bubbles began to appear and the liquid oxygen manifold pressure dropped; 2) as the size and number of bubbles increased, the bulk density decreased and the injector pressure drop increased; 3) atomization improved and the chamber pressure increased; 4) liquid oxygen flow was reduced and manifold pressure increased; 5) bubbles condensed back into the liquid, which reduced the pressure drop and worsened atomization and lowered chamber pressure; 6) manifold pressure decreased because of an increased liquid oxygen flow, 7) bubbles began to appear again and the cycle is repeated.

To eliminate chug, gaseous oxygen or helium was injected into the liquid oxygen propellant line at the manifold inlet flange to produce a foamed liquid of reduced density. The gas was injected through a vacant instrument port and no attempt was made to distribute the gas or control the bubble size. Video into the manifold showed that the bubbles were too fine to see and appeared as a fog. Helium injection of approximately 0.4% of the liquid oxygen weight flow, or oxygen injection of 4% of the liquid oxygen weight flow, eliminated chug over the entire 10-to-1 throttling range. Differences in required flows were due to the difference in gas volumes as well as condensation of some of the gaseous oxygen.

Gas injection restored the performance lost by the chug. In one case, a 7.5% increase in $\Delta p_{inj}/p_c$ to a value of 15% $\Delta p_{inj}/p_c$ eliminated chug at 22% thrust. The increase in pressure drop to stabilize the combustion with injected gas agreed with the increase in pressure drop required without gas. Helium was also injected into the oxygen manifold at rated thrust levels to see if that improved performance, but only a negligible increase was noted.

3. Advanced Throttling Concepts Study (1964) [45,75]

Pratt and Whitney Aircraft also studied a gas injection technique called cross-injection, in which small amounts of storable fuel were injected into the storable oxidizer propellant line and small amounts of oxidizer were injected into the fuel propellant line, which produced combustion gas in the propellant lines. The propellant line pressures were increased, which improved throttling capability. This

study also examined dual-manifold injectors and combined methods of throttling and is discussed in other sections.

Two operational modes were considered using a fixed-area injector. In the first mode, an appropriate mixture ratio (for the secondary cross-injected flow) was determined for a particular thrust to provide a temperature and pressure rise in the propellant line at that thrust level. A significant pressure drop was established across the injector. Since the secondary line pressure remained constant as the propellant flows increased, however, the pressure drop increase returned to that of a fixed injector case, so that this mode was only beneficial over a small thrust range.

The second mode requires control of the secondary propellant flow. The secondary mixture ratio was held constant over a given thrust range (2~20% in this case). The disadvantage of this method was that it required a more complicated flow control, but it would maintain high injection pressures and velocities over the range of interest. Figures 15 and 16 show the effect on injection pressure drop, considering a small amount of secondary oxidizer flow into the primary fuel line.

The cross-injection technique was hot-fire tested with an injector in the secondary line that provided a 90° hollow spray pattern in water flow giving fine atomization. Secondary propellant flow mixture ratios were from 0.003 to 0.009 for the oxidizer-into-fuel case and 147-525 for the fuel-into-oxidizer case. Repeatable and stable results were demonstrated, with only very small amplitude oscillations evident at 10 and 170 Hz.

4. Throttling Concept Study (1965) [76]

The Bendix Corporation investigated the gas injection technique using nitrogen gas with a storable propellant injector. A throttle range of 35-to-1 was demonstrated with nitrogen, and a 50-to-1 throttle range was considered possible using helium gas instead of nitrogen. Combustion was stable and efficiency was preserved over the entire throttle range. This concept evolved into the Bimode Bipropellant Attitude Control System, which was capable of both pulsing and continuous throttling. Attitude control motors normally use maximum thrust to maneuver the vehicle, but stabilization, a much more complex mode, would be much easier with a varying thrust capability. The Bimode concept keeps the advantage of short duration, maximum amplitude, thrust pulses that result in the maximum unaccelerated coasting time.

5. Other Engines

The Rocketdyne SE-10 engine, a competitor to the variable area injector design for the Apollo lunar descent engine, used helium gas injection at low thrust to enable deep throttling [3,19,77]. A 200-500 Hz chug at low thrust, however, as well as intermittent popping, remained present with and without the helium injection. Additional problems with self-induced first tangential modes occurred early in developmental tests, which were solved by implementing a Y-shaped baffle arrangement [78].

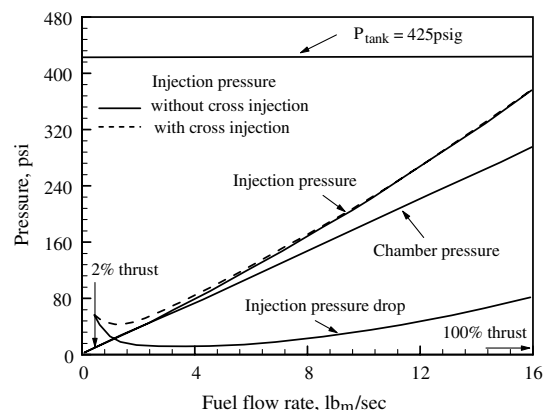

Fig. 15 System pressures versus fuel flow rate with a constant secondary mixture ratio [75].

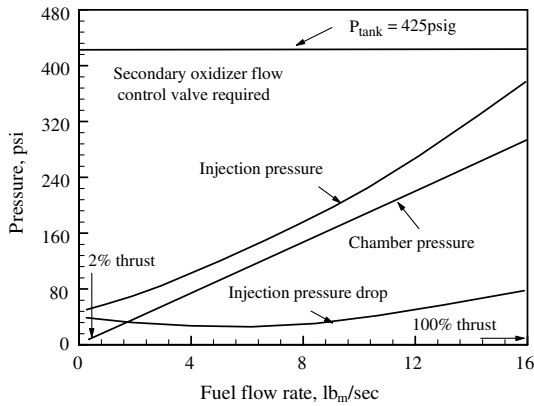

Fig. 16 System pressures versus fuel flow rate with a constant secondary oxidizer pressure [75].

Attitude control thrusters and other very small thrusters (with thrusts of near 1 lb [79]) use the gas injection technique not necessarily to increase the injector resistance to enable deep throttling, but to alter the total flow rate. This is possible because at low thrust, the flow change due to the addition of gas is not negligible as it is at high thrust.

D. Multiple Chambers

The principle of throttling with multiple chambers involves stopping flow through one or more chambers or varying the thrust of each chamber independently. A deeper throttling can be obtained by independently throttling multiple chambers by a small amount. This concept is primarily used in aerospike engines, but has been used in other rocket engine systems as well. Disadvantages include feed system complexity and additional weight, as well as the difficulty in managing propellants and thrust transients during each engine startup or shutdown [19]. Also, stopping flow through individual thrusters on aerospike engines can result in significant thermal issues.

Russian engines often use this feature for reasons other than for throttling [3,80]. It was found that small diameter combustion chambers did not present the stability problems exhibited in larger diameter chambers. With multiple chambers, each chamber diameter could be reduced. Additionally, smaller parts were easier to manufacture, there was an improved capability to provide thrust vectoring, and the overall engine length was reduced. The engine-out reliability was said to be increased because one or more thrust chambers could be shut off and the total thrust could be maintained by increasing the thrust of the other chambers. Multiple chambers do not, however, provide the optimum engine weight.

1. Advanced Thrust Chamber for Space Maneuvering Propulsion Program (1965) [81–86]

The Air Force Rocket Propulsion Lab. at Edwards Air Force Base sponsored a Rocketdyne study in 1965 to investigate a space maneuvering propulsion system to be used for satellite intercept or rendezvous. The engine design included multiple concentric regeneratively cooled thrust chambers. Two multiple-chamber concepts were examined in one engine study. The first concept was the aerospike engine, which could be throttled and contained many small chambers and nozzles. The second concept was a standard chamber with converging-diverging bell nozzle inside of a separate aerospike engine. The outer primary thrust chamber was a toroidal aerospike, divided into segments, producing 30 Klbf thrust, while the secondary inner thrust chamber included a bell nozzle producing 3.3 Klbf thrust.

The development focused on the primary chamber because of the unique toroidal features of the aerospike chamber. It included testing of a full size segment that was 1/47th of the toroid circumference. Short duration tests were performed over a chamber pressure range from 300 to 600 psia, and combustion efficiency remained high.

Analysis and design for the followup Advanced Maneuvering Propulsion Technology Advanced Development Program was initiated in 1967. The final engine configuration is shown in Fig. 17. Both the 3.3 Klbf chamber and the 30 Klbf chamber would throttle 9-to-1, providing a total effective throttling ratio of approximately 81-to-1. Combustion was stable during hot-fire tests of the outer primary chamber segments over a chamber pressure range from 650 psia to 72 psia. Dynamically stable combustion was demonstrated with pulse gun testing. Combustion efficiency ranged from 98 to 100% over the entire throttling range of the tested segment.

2. Other Engines

Many Russian engines have employed multiple chambers, although primarily for combustion stability and ease of manufacturing [36]. The relatively recent RD-170 and RD-171 engines with four thrust chambers and the RD-180 with two thrust chambers each include one turbopump with each engine system. The RD-170 and RD171 provide 1777 Klbf vacuum thrust and can throttle to 56% of maximum thrust, while the RD-180 provides 933.4 Klbf vacuum thrust and can throttle to 40% thrust [3].

E. Pulse Modulation

Pulse modulation, short for pulse-width modulation (PWM), is used predominantly in monopropellant engines. PWM is on-off cycling that provides a quasi-steady-state average thrust. PWM in LREs has its roots in pulse jet engines. The German V-1 guided missile developed in Peenemünde contained a pulse jet engine that was flown for military purposes in 1942 and is most well known for the London bombing in 1944. It was also known as the “buzz bomb” because of the low frequency sputtering sound caused by set frequency pulses at 100 Hz and a resonant combustion response at roughly 50 Hz. The air intake shutters closed as the fuel ignited and gas expanded for a short duration [87,88].

The more recent Pulse Detonation Engines (PDEs) make use of a similar technology, except that PDEs detonate the fuel and oxidizer mixture while the flow is supersonic. While the PDE combustion process is more efficient than PWM, there have been difficulties converting the energy into efficient thrust.

The primary issues related to PWM are fast response valves and low performance. PWM is advantageous, however, when small thrust corrections are needed, as in satellite rendezvous. In PWM, throttling is accomplished with tailoring of the thrust and duration of the pulses. Disadvantages include shock loading on the vehicle, heat soak in the chamber head end, inefficient use of propellant because of chamber cooling channel and injector dribble volume losses between pulses [19]. Additionally, igniting each pulse can be difficult, especially for very short pulse widths.

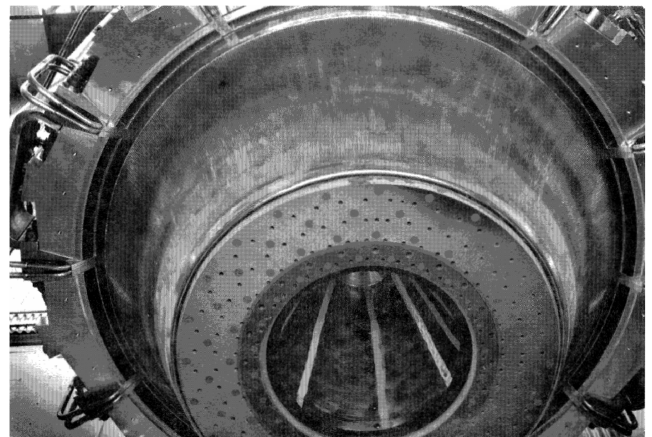
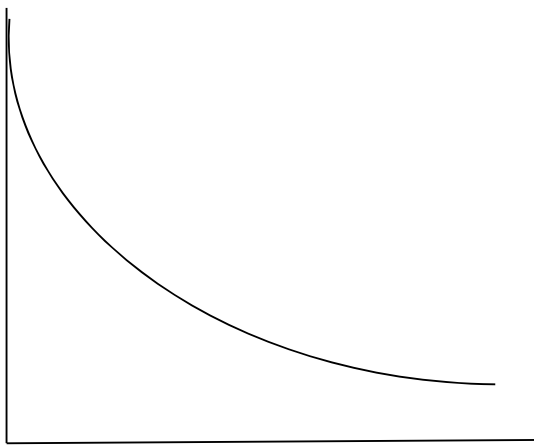

Fig. 17 Advanced maneuvering propulsion technology advanced development engine [81–86].

1. NASA Studies (1959) [89,90]

A 1959 NASA report examines scenarios for rendezvous between two satellites, assuming that one satellite is maneuverable with velocity increments tangential to the orbit. Pulsed thrust was considered for the several maneuvers required for various rendezvous scenarios. The use of fixed-duration thrust pulses, in which pulses provide the necessary total ΔV or total amount of thrust necessary to complete a maneuver, was slightly different from the PWM methodology, which uses numerous pulses at a particular frequency and pulse width to provide an average specific impulse and thrust profile. The single impulsive thrust maneuver capability was developed initially for use in satellite maneuvering.

In 1961 NASA examined a PWM methodology to evaluate a linear system for applying thrust to a maneuverable vehicle in the terminal phase of a rendezvous. The throttleability limitations of an existing rocket engine are not necessarily a major obstacle to the system design of a maneuverable satellite. Maneuverable satellites, however, such as for terminal phase rendezvous systems, would need to employ systems that would provide the same average thrust as a continually variable thrust engine, as illustrated in Fig. 18. The



a) Thrust program for a system

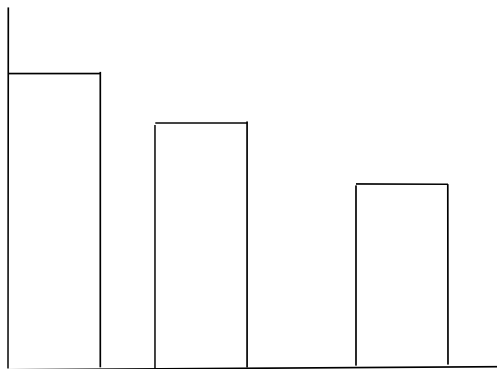

b) Approximation for which thrust interval is fixed and thrust is variable

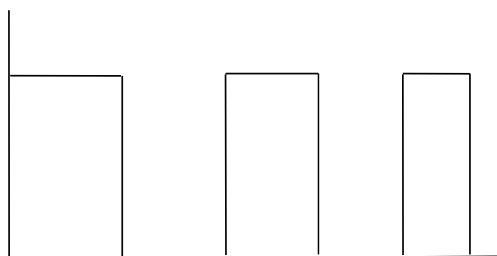

c) Approximation for which thrust magnitude is fixed, but duration is variable

Fig. 18 Pulse-width modulation throttling approaches [89].

average thrust needed to complete a mission, for example, is shown in the first inset. The second inset gives an effective throttling approach by using pulse modulation of a constant width but with variable thrust. The third inset gives an effective throttling approach by using pulse modulation of variable width but constant thrust. Both methods can be designed to provide the same thrust profile.

2. Lunar Flying Vehicle Study (1964) [91]

In 1964, Bell Aerospace Company began development of a 100-to-1 variable thrust engine called the Bell model 8414 Throttleable Maneuvering Engine, for earth orbit, lunar, and planetary spacecraft maneuvering propulsion systems. This engine system combined a continually varying thrust engine and a pulse engine to provide continuous throttling and pulse operation capabilities with maximum performance at highest thrust, where most of the propellant would be consumed. Deep throttling and pulsing performance could be provided without compromising the high thrust performance.

A single fixed-type injector was optimized over the entire thrust range to maintain adequate injection velocities and injector pressure drops for efficient and stable combustion. Gas-injection methods were rejected because of the increased complexity and system weight penalty. Dual-manifold and variable area injector methods were also rejected as too complex, since most of the time the engine operated at high thrust.

A six-element triplet injector was optimized for performance and pulse response. Six was found to be enough elements for high performance and few enough to minimize manifolding volumes for maximum pulse response and pulse performance. Two independent valves were used: a throttling valve and a bipropellant variable area cavitating venturi with an actuation time of 5 ms attached directly to the manifold.

Continuous throttle, without pulsing, was achieved down to 12% of rated thrust. Combustion was controllable, stable, and reproducible. Combustion performance was 94% at rated thrust with maximum specific impulse at 87% thrust. Pulse performance was measured from 100 to 20% rated thrust using pulse durations of 150 msec. Ignition spikes reached a maximum 300% of the rated pressure.

Figure 19 compares the performance curve for pulsing at a set thrust with continuous throttling of a set thrust, and illustrates one of the disadvantages of PWM. There was a major degradation in performance at a specific thrust level due to the short duration time and transient event of the pulse. The reduction in performance at the thrust of an averaged transient pulse as compared with a steady-state set point of equivalent average thrust was not clear, although it was expected to be lower due to reduced performance during the transient. With even shorter pulses, there is more degradation in performance.

The program demonstrated the feasibility of combining single injector throttling with PWM to extend the thrust to deep throttling of 100-to-1. Figure 20 shows the performance over the range of thrust with continuous variable thrust down to 12% thrust and PWM down to 1% thrust.

3. The Bendix Corporation Study (1965) [76]

The Bendix Corporation reviewed the state-of-the-art techniques of pulsing and variable area throttling in 1965. Problems encountered included low combustion efficiency, high electrical power consumption, low response, materials problems, and unwieldy configurations. Specific impulse was reduced when operating in a regime that required short pulse widths. The repeatability and consistency of engine performance was dictated by the control and minimization of fuel usage by the pulsing accuracy. At that time, varying pulse widths using a single thrust level was not successful and pulsing accuracy was not achieved.

F. Throat Throttling

The throat throttling method appears to have been one of the first methods to throttle LREs. Two approaches were defined, including

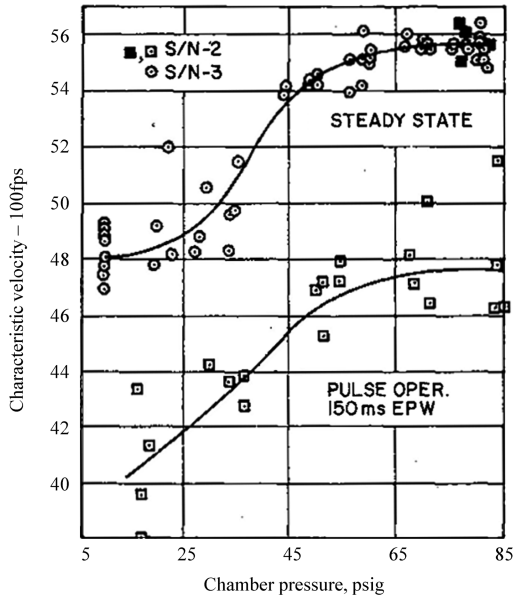

a) Comparison of steady and pulsing performance

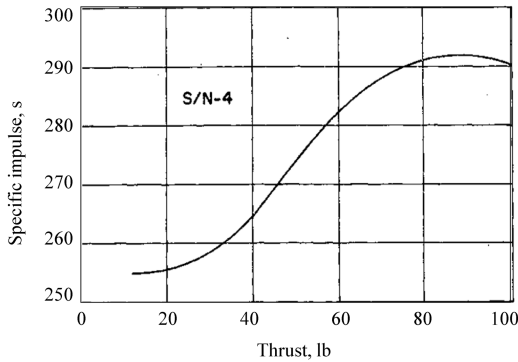

b) Steady performance

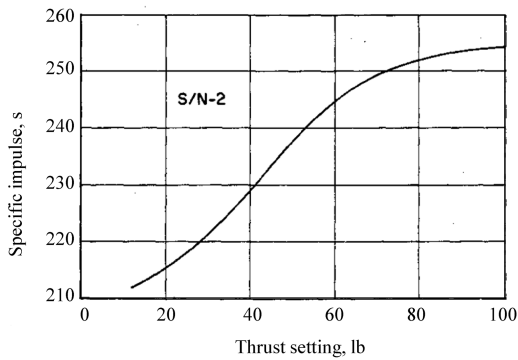

c) Pulsing performance at 150 msec pulse-width

Fig. 19 Pulsing performance comparisons [91].

use of a cooled mechanical pintle inserted and retracted through the nozzle throat, and injection of gas into the throat region. Both methods effectively changed the throat area by providing some blockage into the flow field. Both modes have a net effect on decreasing thrust, since at constant propellant pressures, a throat restriction causes an increase in chamber pressure and hence lower injection pressure drops and reduced propellant flow rates. Because of the high chamber pressures at low thrust, there is an associated maximum theoretical performance at low thrust. The major concerns related to throat throttling are excessive vibrations and heat transfer of the pintle. In addition, high injection pressure drops are required at full flow conditions to maintain minimum pressure drops at low flow rates, and a high-pressure propellant feed system is necessary. Because of material limitations, an uncooled throat pintle was

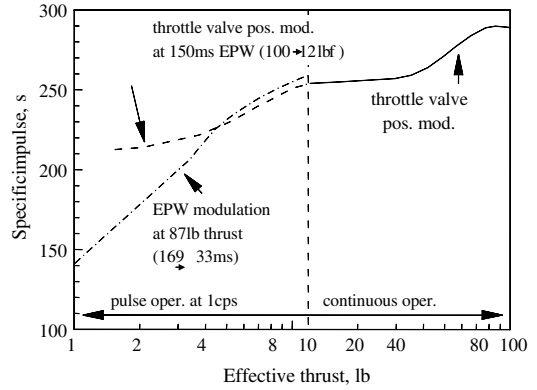

Fig. 20 Dual-mode throttling performance [91].

historically not an option, but there are now higher temperature material and thermal coatings available.

1. Reaction Motors, Inc. Study (1947) [92]

Reaction Motors, Inc., developed a small acid-aniline propellant variable thrust LRE using a throat throttling device called a bulb or restrictor to vary the area of the throat, as shown in Fig. 21. The throat area was varied by inserting and retracting the restrictor, which was internally cooled by flowing fuel through the center shaft and the restrictor bulb. Materials that could withstand the engine temperature were not available to allow an uncooled design. The cooling fuel was then fed into the injector elements. The nozzle and chamber walls were cooled by the oxidizer, which was then also fed into the injector elements.

With a varying throat area needed for a throttle range of 6.25-to-1, the L^* also varied from 43.5 to 272 in. A compromise L^* design range was chosen for a single constant volume chamber. Propellant flow rate was also controlled to maintain constant chamber pressure based on the nozzle throat area using a closed-loop control system.

The nozzle throat area was originally varied with a restrictor bulb that gave poor expansion ratio characteristics at low thrust, but this was later improved. In one test large vibrations occurred thought to be due to injector valve flutter. Stiffer propellant valve springs were to be incorporated in future designs. Only a few tests were performed an only at 60 and 75% thrust, because of broken lines and severe vibrations. Limited performance information was therefore obtained.

2. Massachusetts Inst. of Technology Naval Supersonic Lab. Study (1961) [93]

The Office of Naval Research sponsored research in the Naval Supersonic Lab. (NSL) at Massachusetts Inst. of Technology for throttling by gas injection into the nozzle throat. The primary flow, injected into the chamber, was most susceptible to secondary gas



Fig. 21 Reaction Motors, Inc., restrictor device [92].

injection at the nozzle throat. The influence of the symmetric secondary flow at this location was strongest because it had a significant effect on the throat effective area. The total flow ratio, or the ratio of primary flow injected into the chamber plus the secondary flow to the primary flow with no secondary flow, was unity, which indicated that the exhaust velocity did not change with injection rate and the flow behaved as though throttling was accomplished by varying the throat area. Three separate models were developed to analyze this throttling method. The models of Martin [94] were the first analytical solutions to this flow throttling problem, but disagreed with the NSL data. In [93] an improvement to these models was made. The two models based off of Martin's work were the secondary mixing model and the sheet flow model. A newer model, the secondary expansion model, was also developed. Basic assumptions to these models include one-dimensional flow, perfect gas, and isentropic flow. Two-dimensional and three-dimensional airflow investigations validated aspects of all three models. Schlieren photographs showed that all three types of flow occurred.

In addition to these three models, a flow analogy was developed and other pertinent variables investigated. The analogy treated the secondary flow as a blunt body and then combined the two flows with matching boundary conditions. Three variables investigated were temperature, secondary injection gas type, and combustion. There was a significant effect as the secondary fluid stagnation temperature was reduced to below the primary flow stagnation temperature. Throttling was ineffective for a secondary stagnation temperature 5 times less than the primary stagnation temperature. This effect was also evident in Rocketdyne testing on the F1 engine and additionally in United Aircraft Corporation (UAC) thrust vectoring experiments [95]. Rocketdyne showed that a stagnation temperature ratio of 4 did not throttle the primary flow. UAC showed that the effectiveness varied with the square root of the secondary-to-primary stagnation temperature ratio. The high temperature of the secondary working fluid seems to limit the practicality of throat throttling with gas injection.

The type of injection gas also had an effect on throttling behavior. A low specific heat ratio and low molecular rate were desirable properties of the secondary gas because of the low molecular weight and low specific heat ratio of the combustion gas. Helium showed the most potential as a throttling secondary gas because of its low molecular weight.

Other variables examined were injection angle, nozzle throat pressure gradient, and secondary flow injection location. Throttling increased with decreasing injection angle, the angle between the nozzle axis and the injection axis. A reduction in the nozzle throat pressure gradient had a small effect on increasing flow throttling.

3. Other Engines

A February 1946 Aerojet report (Rept. No. RTM-20) described the development of a 100 lb thrust nitromethane monopropellant variable thrust engine. A stainless steel pintle was moved into the nozzle throat to vary the thrust 10-to-1. Performance was measured only at 65% and 100% thrust. A 1948 M.W. Kellogg report (Rept. No. SPD-156) described and presented a highly complex injector design that showed the throat throttling methodology. The throat was throttled by a pintle and the injector. The injector contained movable concentric injector rings. A 1950 Univ. of Michigan report (Rept. UMN-71) discussed variable thrust engines with throat throttling, and concluded that the method was not feasible because of low pressure drops at low thrust. The report also stated that combustion instability would be likely with the RFNA and aniline propellants in an engine with a 100 in. L^* . The variable L^* was not taken into account. An analytic study of variable thrust LREs was performed by the Army Ballistic Missile Agency on the Redstone Arsenal in Alabama in 1961 [96]. The analysis compared the relative efficiencies between a variable throat area nozzle and a fixed nozzle geometry for storable propellants. The report concluded that there would be a 10% weight savings of propellant due to the performance increase gained with the variable throat area nozzle, but that this was insignificant to the overall vehicle weight.

The underlying assumptions of the configurations and model were not provided.

G. Variable Area Injectors

The variable area injector is often referred to as a pintle injector because the majority of variable area injectors contain a single central pintle feature that is moved to vary the injector orifice area. The maximum thrust occurs when the injection orifices are fully open. As the injection area is reduced using movable injector components, the chamber pressure and thrust are reduced. Pressure drop increases as the engine throttles down because of the decreasing injection area, which results in high injection velocities and good atomization and high combustion efficiency over a wide throttle range. The most familiar variable area injector throttleable engine is certainly the Apollo Lunar Module Descent Engine (LMDE).

The major advantage of this method is its design simplicity, although there is some complexity to the actuating and guiding elements. Design requirements are sometimes conflicting; different injector pressure drops are needed for throttling chug stability and maximum combustion efficiency. An optimization based on mission requirements provides the tradeoff between performance and throttling capability. Generally there is a need for flow control valves in conjunction with variable area injection for complete mixture ratio and throttling control. Performance efficiency may not be as high as it would be in a multielement injector.

1. Variable Thrust Engine Development Program (1950) [97]

Reaction Motors, Inc., examined variable thrust pressure-fed engine designs based on injectors previously tested under the U. S. Navy's Bureau of Aeronautics (BuAer) and the U. S. Air Force. Four injector concepts, representing methods of controlling the relationships of propellant flow rates, injector pressure drops, and chamber pressure, were examined. The first injector concept used a single controllable valve that changed the injector annulus area of one propellant. The second injector concept used a single controllable valve for both injector holes. Atomization was promoted by having radially injected propellants impinge on a splash plate. The third injector included valve control of the axial movement of a flow selector piston that covered or uncovered small holes permitting selection of specified flow. The propellant streams impinged on a splash plate before injection into the chamber. The fourth injector concept consisted of two poppet valves. The variation of propellant inlet pressure gave a wide flow range for a prespecified smaller range of injector pressure drop, which was accomplished by balancing the pressure drop with poppet spring forces.

2. Project MX-794 (1951) [98]

As follow-on to the propellant throttling study described in a previous section, two additional progress reports were published by the Willow Run Research Center at the Univ. of Michigan. The second and third progress reports evaluated the variable area throttling methodology.

In the second progress report, an injector was converted into a throttling injector by using a plunger whose movement simultaneously covered or uncovered both propellant ports, thus keeping the mixture ratio constant and the propellant flow rates controlled from a constant supply pressure. Multiple swirl injectors with various size propellant orifices were tested to obtain performance information for a particular injector design configuration. The best performing injector was converted into a variable area injector. Continuous throttling was achieved over a range of 27-to-1. With a constant supply pressure, the pressure drop increased as the engine throttled down, which minimized rough burning at low chamber pressures. The throttleable injector showed lower performance than single thrust injectors tested with various size injection orifices, and the condition worsened as propellant flow decreased. This result was attributed to the result of improper mixing due to the changing of the propellant entry angle. Covering of orifices by the plunger altered the entry angle of the flow so that less mixing was obtained.

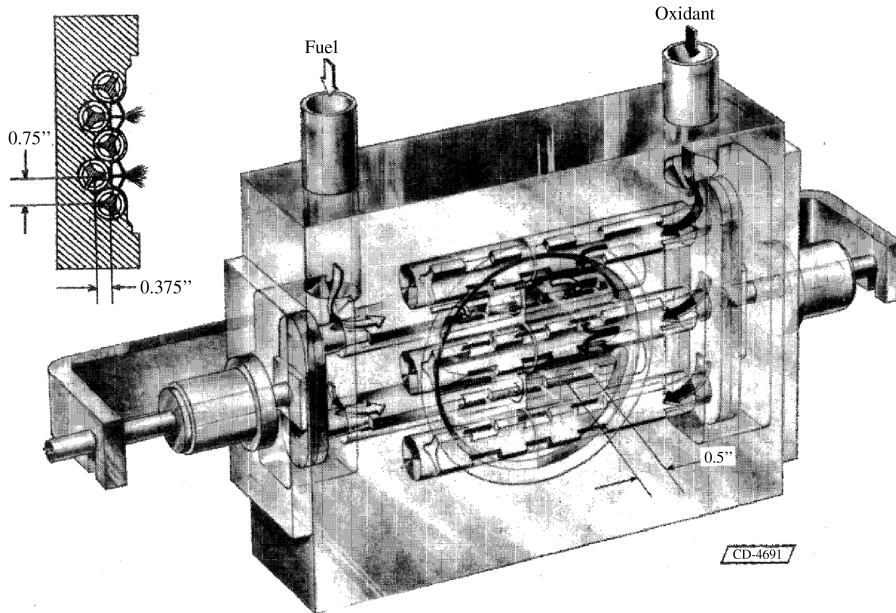

Fig. 22 Triplet impinging-jet variable area injector [99].

In the third progress report, different size injectors, different types of injectors, and different propellants were tested. The same remotely controlled plunger was used to cover and uncover the propellant orifices. Continuous throttling was achieved over a 35-to-1 range for the lower thrust engines and 6-to-1 for the larger thrust engines. Triangular orifices maintained a constant geometric shape, as the plunger covered or uncovered the holes, which provided better flow control at low flow rates, although the holes were difficult to fabricate. The other injectors had circular or rectangular orifices.

High frequency combustion instability was encountered at higher chamber pressures with the low thrust WFNA and jet fuel propellant combination. The instability was eliminated by increasing the chamber contraction ratio from 8-to-1 to 16-to-1. The chamber diameter was increased and the chamber length was decreased with a net increase in L^* .

For the midrange thrust development tests, the propellant supply pressure was constant, which allowed the pressure drop to increase with decreasing chamber pressure, and the mixing and spray formation to improve at lower propellant rates. No combustion instabilities were experienced even after reducing the pressure drop by lowering the propellant tank pressures. In one case the plunger seized, which was corrected with an o-ring seal between the plunger and the injector body.

3. NACA Study (1955) [99]

An investigation to examine the performance and operating characteristics of two variable area injectors over a wide thrust range was conducted by Tomazic in 1955. The first injector was a triplet impinging-jet injector with six groups of 10 triplet sets; each group was controlled by a pneumatic valve actuator, which varied the number of triplet sets that were open. The second injector was a swirl-cup injector in which two fuel entry holes and two oxidizer entry holes injected the propellants in a swirl pattern into a cup. The orifices were arranged alternately 90 degrees apart. A movable piston formed the bottom of the cup and was moved by a pneumatic valve actuator. The piston moved over the entry holes to change the area. Schematics of the two injectors are shown in Figs. 22 and 23.

The triplet impinging-jet injector was tested over a thrust range of 12-to-1 and the swirl-cup injector was tested over a thrust range of 18.5-to-1. The triplet injector had 96% efficiency at full thrust, but efficiency decreased steadily until 20% thrust, where it decreased sharply. The swirl-cup injector had 90% efficiency at full thrust, but its efficiency also decreased sharply below 20%. Figure 24 compares combustion efficiency for the two injectors.

One difficulty in this setup was leakage around the pistons, which degraded the spray pattern and altered the mixture ratio. The performance drop in the triplet injectors was attributed to this leakage and poor mixture ratio control. The performance drop in the swirl-cup injector was attributed to poor mixing at low thrusts, as was demonstrated in water flow tests.

4. Lunar Module Descent Engine Program (1963) [19,78,100-103]

The best known throttleable engine in the United States is certainly the Lunar Module Descent Engine (LMDE). Engine development began in 1963 and man-rated qualification was completed in 1967. The engine was first used on Apollo 5 in an unmanned configuration in January 1968, and then on Apollo 9 for a manned flight in March 1969. On Apollo 11, the engine landed astronauts Neil Armstrong and Buzz Aldrin on the surface of the moon. The engine was also used to return the astronauts of Apollo 13 to an earth orbit

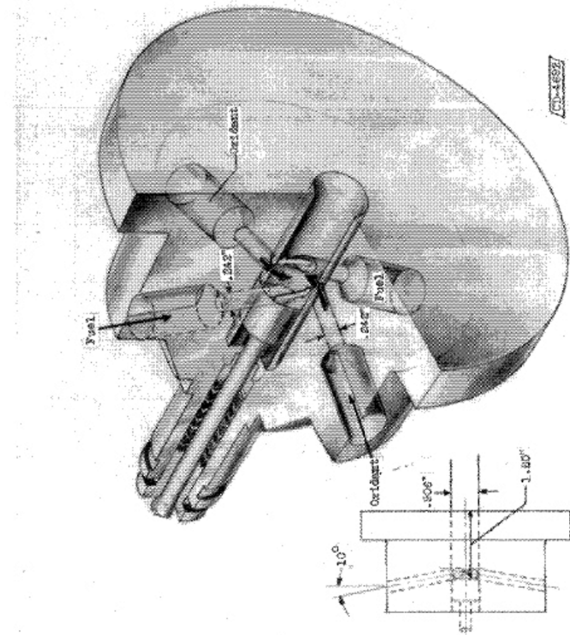

Fig. 23 Swirl-cup variable area injector [99].

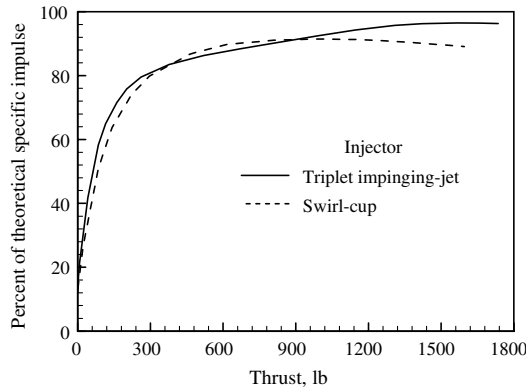

Fig. 24 Theoretical specific impulse for triplet impinging-jet variable area injector [99].

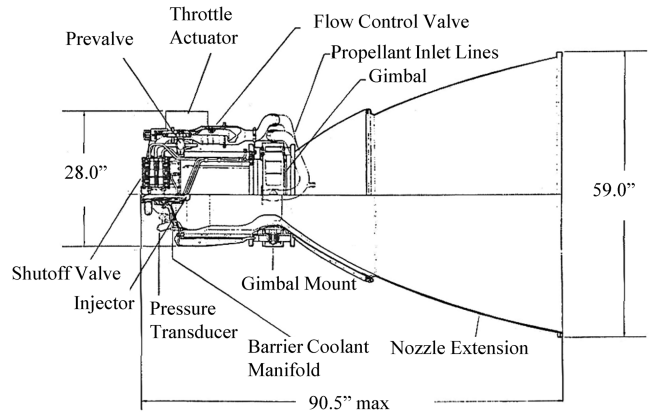

Fig. 26 LMDE engine layout [100,101].

from a lunar orbit after an oxygen tank failure damaged the service module.

The operating requirements of the LMDE included a 10-to-1 throttling capability. The nominal LMDE duty cycle included a 33-s orbit injection burn, an hour on-orbit coast, and a 784-s descent burn, as shown in Fig. 25. Both engine burns started to 10% thrust while the vehicle was stabilized. The descent firing included a full thrust braking phase and a 60% thrust braking phase, followed by a slow reduction to 40% thrust during vehicle flareout, and reduction to near 25% during the hovering phase.

The engine is illustrated schematically in Fig. 26. Fuel cooled the injector faceplate and flowed into the combustion chamber out of the annular orifice of the pintle injector element. The annular orifice was created by an extension of the injector face and a moveable sleeve. A small portion of the fuel was injected along the side of the chamber wall through 30-six tubes. The oxidizer flowed through the center of the pintle and was injected radially near the tip through 30-six holes. Movement of the fuel sleeve varied the injection area of both the fuel and the oxidizer.

Three fundamental requirements for the descent engine system were 1) accurate mixture ratio control over the entire thrust range, 2) controlled injection for performance and combustion stability over the entire thrust range, and 3) simplicity of moving parts. Two solutions were employed to meet these requirements. First, the propellant flow control was separated from the propellant injection functions, which allowed optimization of each without one compromising the other. Second, an injector with a centrally located single element pintle contained a single moving part to vary both the oxidizer and fuel orifice areas. This solution provided the greatest design simplicity.

One disadvantage with variable area injectors is the inability to control mixture ratio; as the injector orifice area changes, the mixture ratio can change as well. The method used to control the mixture ratio

in LMDE was to incorporate variable area cavitating venturis in the propellant lines in addition to the variable area injection orifices, which ensured that the propellant flow rates would be insensitive to variations in downstream pressures that resulted from injector orifice area changes. Provided the manifold pressure stayed below the pressure required for cavitating flow, the flow rate would remain constant. The cavitation regime was active only below 70% thrust; otherwise the propellant flow was controlled by the pressure drop of the entire system, which eliminated the large pressure loss penalties associated with high cavitating flows.

Combustion instability was addressed by positioning the single element injector in a region that minimized coupling with tangential acoustic modes of the chamber. A centrally located injector element would be most stable for a tangential acoustic mode, which has a pressure node line through the center of the chamber and is most resistant to a driving combustion forcing function at this location. On the other hand, a centralized element injector would be susceptible to a radial acoustic mode, which has an antinode in the center of the chamber. Neither radial nor tangential modes were detected from over 2800 tests including 31 bomb tests. The first radial mode may not have been excited because the reaction zone was annular rather than concentrated exactly in the center of the chamber. Low frequency pressure oscillations were present during throttling transition, with 20 psi peak-to-peak in the 10 to 100 psi chamber pressure range.

Performance remained relatively high over the throttling range, as shown in Fig. 27.

5. TRW, Inc. Studies: MIRA 150A (1965) [104-107]

The MIRA 150A variable thrust rocket engine was designed for attitude control on the Surveyor spacecraft. The engine was ablatively cooled because of the incompatibility of available coolant flow over the entire 5-to-1 thrust range. The injector was a single

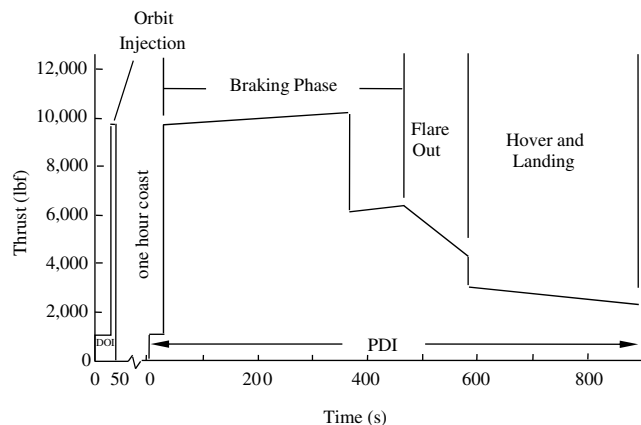

Fig. 25 LMDE nominal duty cycle [19,78,100-103].

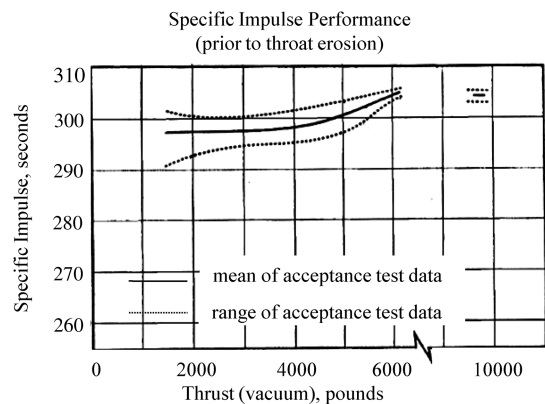

Fig. 27 LMDE engine specific impulse before throat erosion [100].

element coaxial tube pintle. A single moving sleeve provided variable area control to the annular propellant orifices. Propellant flows were also controlled by variable area cavitating venturis upstream of the injector orifices. The NASA MSFC later selected MIRA 150A as one of two engines to be evaluated for a lunar exploration flying system. The injection velocities were reoptimized for a new propellant combination. A total of 84 starts with 4 engine configurations demonstrated deep throttling (6.8-to-1), chamber durability, ballistic performance, and dynamic response.

6. Gaseous Propellant Throttling Rocket Engine Study (1965) [108–112]

Several gas injection rocket engine experiments were performed at a rocket engine test facility at the Air Force Inst. of Technology (AFIT) located on Wright-Patterson Air Force Base in Ohio. Although this study does not use LREs, the features of this mode of throttling are very similar. The variable area injector throttling method was selected since it was most suitable for the design requirements and was compatible with the test facility at AFIT. A small engine was designed for 10-to-1 throttling based on a constant thrust engine design by Ow [112]. The modified throttleable engine incorporated a new injector plate and 3 movable pintles. Movement of the central pintle regulated the oxidizer flow while movement of the other two pintles regulated the fuel flow. Ethylene propylene rubber seals were used between the movable pintles and the injector front cover plate. The engine assembly schematic is shown in Fig. 28. Fuel was injected radially through the side walls of the entire chamber and acted also as film coolant. The two variable area fuel orifices were located upstream of the film coolant manifold. The self impinging oxidizer was injected through a central orifice that was controlled by the central pintle.

The injector was later redesigned as a twin orifice showerhead injector, which solved facility issues. There was one orifice in the chamber for fuel and one orifice for oxidizer on the opposite side. Two plates slid over each propellant orifice to define the basic throttling mechanism. The engine was throttled 4.1-to-1. Combustion efficiency increased at lower thrust levels.

Another modified variable thrust rocket engine incorporated a variable area injector using gaseous propellants. The propellant lines included separate orifices, one for each propellant, and again plates slid over each propellant orifice. The impinging injector face contained one central hole for the oxidizer and ten surrounding holes for the fuel, angled so that impingement occurred roughly 2 in. from the injector face. Throttling over 7-to-1 was achieved. Steady-state set-point tests demonstrated that the overall performance remained nearly constant, with a very slight drop-off of specific impulse. The c^* performance was highest at the low throttle conditions and was attributed to the longer gas molecule chamber residence time.

A hydraulic control system was later implemented to actuate the throttling mechanism. The engine response to transient throttling

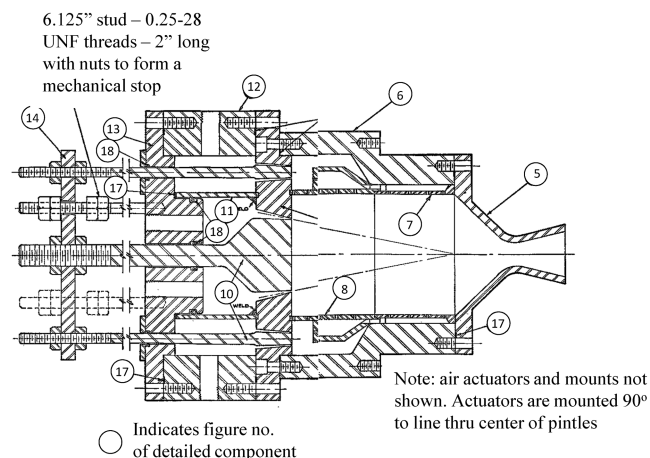

Fig. 28 Gaseous propellant variable area injector engine schematic [108].

over a thrust range of 5-to-1 was examined. Impulse throttling showed that it took longer for the decreasing percent throttle tests than for the increasing percent throttle tests to return to steady-state performance values. This was attributed to flow pressures in the manifold and resulting friction forces. There were never any indications of combustion instabilities for any of the tested configurations, however, it was not clear as to whether this was due to the throttling technique or the gas propellant injection.

7. Deep Throttling TR202 (2005) [113–115]

Northrop Grumman Space Technology (NGST) is currently developing the TR202 engine, a closed expander cycle engine with independent turbopumps and a variable area pintle injector, for technology development of a cryogenic propellant applicable to the lunar descent engine. The independent turbomachinery and variable area pintle would enable full control over mixture ratio and thrust. Injector tests have been performed at NASA Marshall Space Flight Center. Stable combustion performance was demonstrated with a pintle injector at several setpoints over a 10-to-1 throttling range with LO_2 and GH_2 propellants.

The pintle injector would control the core and wall mixture ratios and maintain acceptable injection propellant pressure drops, which should provide high combustion efficiency and combustion stability over the entire throttling range. An illustration of the pintle concept is shown in Fig. 29. NGST is addressing several technology challenges, most relating to behavior during deep throttling, including acceptable injector performance, continuous and deep throttling with cryogenic propellants, stable combustion, acceptable cooling, balancing injector resistance with pump performance and pump exit pressures during throttling, maintaining mixture ratio at desired levels, avoiding pump stall at low flow conditions, and developing deep throttling turbopump technology. Most of these issues are general concerns for any deep throttling technology.

The injector will be developed to a 10-to-1 throttling range and the data used to update the engine design based on program throttling needs. As the engine throttles, the fuel hydraulic pressure drop ratio will increase because the density is a strong function of temperature. The oxidizer hydraulic pressure drop ratio will also increase because the variable area injector orifices are sized for a specific pressure drop. The hydraulic pressure drop ratio will range from 20% at full thrust to 106% at minimum thrust. This has no effect on the cycle balance, because there is more power margin at lower throttle settings. The ability to control mixture ratio over the throttling range provides the ability to maximize propellant utilization, and the ability to control injector resistance eliminates the possibility of chug or high oxidizer pump exit pressures at high thrust.

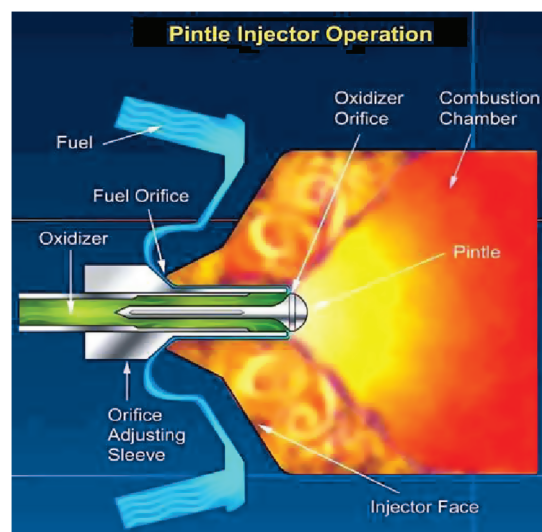

Fig. 29 Pintle injector operation illustration [113–115].

H. Hydrodynamically Dissipative Injectors

Hydrodynamically dissipative injectors use fluid dynamic methods to create adequate impedance across the injector. Methods to do this include use of capillary tubes, which create a high-pressure drop by means of viscous losses, or long element features to create added fluid mass or inertance as additional impedance. The most common method, widely used in Russia [116], is to use swirling vortex tubes to effectively alter the discharge coefficient over a throttling range, in combination with propellant throttling [4,117]. A dual-manifold approach is used in combination with this technique. These methods ensure that the injector is free of moving parts, although additional valving is necessary in some cases. Hydrodynamically dissipative injector methods are usually subsets of other methodologies, such as high-pressure-drop injectors or dual-manifold injectors.

A swirl injector with a two-channel liquid oxidizer system was designed and successfully tested at the Pennsylvania State Univ. with expert advice from visiting professor Vladimir Bazarov in 2001 [118,119]. The tangential-entry dual-inlet swirl injector, a common Russian design, is effectively a dual-manifold injector. Throttling is performed by independently controlling flow through the two channels. Throttling behavior is quantified not only by mass flow variation, but also by variations in injector discharge coefficient. A vortex tube is formed inside the injector element by considering element design and managing preinjection swirl flow. The theory shows how controlling the hydraulics inside the injector element influences the discharge coefficient. Single throttle point experiments were conducted over a 10-to-1 throttle range, and continuously throttling experiments were conducted by continuously varying propellant flow rates over a wide operating range during a single run.

Chug (45 Hz with harmonics) was observed at the lowest chamber pressure while the dual-element injector was in single-channel operating mode. This instability, attributed to very long (33 ft) feedlines and inadequate pressure drops, degraded performance at this operating point. The chug oscillation appeared occasionally during transient runs and also occurred at the transition between two-channel operation and single-channel operation, but that could have been attributed to the closure of the LO₂ valve.

Performance efficiencies were reduced during chug instabilities but also at high throttling conditions. The performance degradation at high throttling was shown to be possibly due to poor mixing caused from a fuel-oxidizer momentum imbalance. Much better performance was obtained when the straight shearing gaseous fuel injection plate was replaced with the swirling injector plate, giving an adequately sized swirl jet.

I. Combined Methods

Some throttling methods, such as variable area injectors or hydrodynamically dissipative injectors, combine techniques to use advantages from each particular method and provide even deeper throttling. Variable area injectors commonly use valves in the propellant lines for additional flow control. Hydrodynamically dissipative injectors combine propellant throttling, dual-manifold injectors, and variable discharge coefficients. Dual-manifold throttling requires propellant throttling. The pulse modulation by Bell Aerospace, described in an earlier section, combines high-pressure-drop injectors for 12-to-1 throttling and pulsing methods to increase throttling to 100-to-1. Most methods require propellant throttling to some extent. Other throttling technology combinations are also possible.

A combination constant area injector and variable area injector, as contradictory as it sounds, was investigated in the Advanced Throttling Concept Study by Pratt & Whitney Aircraft in 1964 [45,75]. This study also examined dual-manifold injectors and gas injection and is discussed in earlier sections. The intent of this study was to evaluate injector systems that provide high combustion performance during deep throttling (specified down to 50-to-1). The injector, called the biproportional area spring (BIPAS), was operated in two distinct modes. At low thrust levels it acted as a variable area

injector to maintain a constant pressure drop, and at high thrust levels it had the characteristics of a constant area injector with variable pressure drop. This allowed for a reasonable injector pressure drop over a wide thrust range while providing enough injector resistance at high thrust to prevent low frequency instabilities. The spring rate of the poppet valves and the location of a physical stop restricting the poppet valves could be changed based on the stability characteristics of the engine. This injector design was not selected for demonstration testing, although it appeared to be superior to the variable area injector.

III. Summary

A. Summary: High-Pressure-Drop Injectors

Project Thumper, one of the first extensive deep throttling investigations, touched on many of the issues related to throttling with a fixed-geometry injector. Performance was reduced at low power levels due to poor combustion at low chamber pressures, mainly because there was insufficient injector pressure drop to sustain good atomization and mixing of the propellants. Instabilities were discovered at lower chamber pressures, including whistling (high frequency combustion instability), motorboating (chug), and hydraulic instability. The instabilities increased the heat transfer rates to several times greater than expected without instability. Studies showed that the fuel in a regeneratively cooled chamber would vaporize at low pressures, and in general, cooling ability was decreased at lower thrusts.

Similar characteristics were observed in other fixed-geometry injectors from other programs, including the sequence of instabilities as chamber pressure was reduced and the increase in heat transfer during instability. High-pressure-drop injectors have performed better than low-pressure-drop injectors in terms of stability and performance during throttling. Several other solutions were proposed to improve stability, including reducing the injector area if pump head rise was available, providing heat transfer to increase the amount of vapor in the manifolds and thus increase resistance, and providing gas injection into the liquid manifolds, which also increases resistance. Low frequency system instabilities occurred when coolant flow vaporized inside the coolant jacket.

Rapid transients over the throttling range were also investigated. In a pump-fed system, throttling from high thrust to low thrust could stall the fuel pump. Other pump-related concerns during throttling included rotordynamic stability, running at shaft critical speeds, high-pressure fuel turbopump thrust bearing lift off, hydrostatic bearing of the high-pressure oxidizer turbopump running in the stall region, freezing turbine gas, sustaining a satisfactory axial thrust balance, bistability of the high-pressure oxidizer turbopump boost pump, and performance of the turbopumps at low flow-to-speed ratios. Nozzle sideloads during the start and shutdown from low thrust were also concerns.

B. Summary: Dual-Manifold Injectors

There are several common themes that occur in dual-manifold injector systems. In general, higher performance efficiency can be achieved at low thrust levels because the injector can be designed with high injection velocities at low thrust, so performance is acceptable, and high injector resistance, so stability is acceptable. Typically the oxidizer side or liquid side contains the dual manifold, because that circuit is generally the driving mechanism for combustion instability. Complexity is increased over high-pressure-drop injectors because of the additional control valves.

There are combustion stability and operational concerns at the transition point. Instability at the transition point has also occurred at low thrust, where only one manifold operates. In one case, chug was attributed to liquid flowing into the secondary manifold and compressing the trapped gas inside. The chug was eliminated by bleeding the secondary manifold to remove the gas. In another case, instability was incited by two-phase flow entering the secondary injector orifices and becoming trapped after the secondary injector control valve was closed, and again was eliminated by releasing the

trapped injector purge gases in the secondary manifold. The selection of the transition point is a compromise to obtain adequate injector velocity from the secondary injector for good propellant mixing and conformance to limiting system pressures, as well as providing adequate stability margin. Complete closure of the secondary manifold can cause overheating of the secondary manifold, depletion of propellant from the secondary manifolds, and contamination of the unprimed secondary manifold with combustion products. Low thrust over a long period of time can deplete the secondary manifold propellant and cause a significant time delay and lower thrust for diversion of primary flow to reprime the secondary manifold.

Other design challenges include the transient system response during flow from low thrust to high thrust, because of the necessity of priming the secondary manifold. The proposed method to obtain a fast response during the transition is to continuously flow fluid through the secondary manifold, either by a bleed flow through the secondary valve or a bleed flow from the primary fluid flow. Injector volume is typically minimized to generally ensure adequate flow response during throttling.

Stability and performance can be optimized by optimizing the flow splits between the primary and secondary manifold. In one example the secondary injector flow was not pumped evenly from the injector, which caused an uneven mixture ratio distribution in the chamber.

The throttling heat transfer results indicate that a transitional and/or a laminar boundary layer may be encountered in the nozzle region at some point over the throttling range. This transition would likely occur if the ejector system could not replicate vacuum conditions adequately. The total chamber heat load generally fits over the entire throttling range with the classical heat transfer correlation of $p_c^{0.8}$.

C. Summary: Gas Injection

The primary advantage of the gas injection method for large thrust engines is the maintenance of a high injector pressure drop over a wide throttling range by a lowering of the propellant bulk density. This method has been shown to eliminate instabilities by increasing injector resistance, and is generally only necessary when operating at low thrust. For very small thrust engines the additional flow can increase thrust. Additionally, performance is not reduced during throttling, and in fact may increase, due to the increased pressure drop as well as increased mixing from an aerated propellant. In most cases, however, the added weight and complexity of gas injection hardware, including valving, piping and control systems, will reduce the payload gain from any performance increase. As a minimum the gas should be tapped off another system, such as the tank pressurant. The gas injection flow rate can be optimized for both performance and stability, but the flow rates required are generally less than 1% of the propellant flow.

The gas injection device must be designed so that smooth homogeneous gas injection occurs. In one water flow test, feed system instability was created by the surging of gas into the injector manifold. Maldistribution or nonuniformity of the aerated propellant could cause mixture ratio variations and local hot and cold regions in the combustion chamber. And lastly, one interesting technique used combustion in the propellant lines to lower the density and produced stable and repeatable results. This technique posed the obvious challenge of trying to control reaction rates in the propellant lines.

D. Summary: Multiple Chambers

The primary advantage of throttling with multiple chambers is that a deeper throttling can be achieved by controlling the thrust of each chamber independently. Multiple chambers are commonly used in Russia for reasons not specific to throttling, primarily for combustion stability and manufacturing advantages. The obvious disadvantages include the feed system complexity and less than optimum weight. Aerospike engines can take advantage of using multiple chambers. Multiple small chambers make up banks that can be independently throttled in the aerospike engine.

E. Summary: Pulse Modulation

The objective of pulse modulation is to obtain a thrust profile by using pulses of various thrust levels and durations. Two typical modes of operation include obtaining a thrust profile by using pulse modulation of a constant width but varying thrust level, and obtaining a thrust profile by pulse modulation of a constant thrust for each pulse but with varying pulse width. A fast response valve is essential to providing pulses of propellants into the combustion chamber. A small manifold provides maximum pulse response and pulse performance.

The performance from a pulsed thrust operating point is usually lower than that of an unpulsed or continuous operating point, due to the effect of including the transient as a significant portion of the duration in the overall impulse. The poorer mixing and atomization during the transients lower the average performance of the pulse. Disadvantages also include shock loading on the vehicle, heat soak in the chamber head end, inefficient use of propellant due to the chamber cooling channel, and injector dribble volume losses between pulses. Ignition of each pulse can be a concern, depending on the pulse rate.

Having the ability to pulse can provide extreme throttling capability. Combining pulsing with continuous operation has provided throttling to 1% of maximum thrust, but due to performance degradation while in pulse mode, most of the mission should be executed at high thrust during continuous operation.

F. Summary: Throat Throttling

The throat throttling method is unique, in that it provides the highest performance and chamber pressure at low thrust. There are many disadvantages with this method, however, including cooling the throat pintle and preventing excessive vibrations of the pintle. An uncooled throat pintle was historically not an option, because of material limitations, but there are now higher temperature material and thermal coatings available. The pintle could also be regeneratively cooled.

Performance losses have been attributed to gas separation in the nozzle cone because of the location of the pintle, which was verified visually with exhaust gas directed at steeper angles during throttling. An optimized pintle device shape would be important to obtain maximum performance. The effect of pintle design on nozzle coefficient should be investigated to obtain the best performance during throttling. Additionally, for a constant pressure propellant system, it would be impossible to obtain optimized atomization and mixing with this method because there is not an adequate pressure drop across the injector over the full range. A compromise must be made in chamber size because there are large variations in L^* due to the varying throat area. At low thrust, the L^* is much higher and allows for more complete combustion, which improves efficiency. Combustion instabilities are a concern at low thrust, even with the high chamber pressure, because the injector pressure drop is small at low thrust. A high rate of thrust change can be designed by incorporating a good hydraulic system for the pintle device.

Finally, throat throttling by means of gas injection into the nozzle throat does not immediately seem practical. The major drawback is the required high temperature needed for the injected gas. In the ideal configuration, the injected secondary gas would have a low specific heat ratio, a low molecular weight, and a high temperature, and be injected at the throat.

G. Summary: Variable Area Injectors

The variable area injector methodology is the most familiar throttling method, because of the legacy of the LMDE. The major advantages of variable area injectors are their relative simplicity and the few incidences of high frequency combustion instability. The resistance to high frequency combustion instabilities probably occurs because the location of energy release from the center-mounted pintle injector minimizes coupling with the tangential and first radial acoustic modes.

Disadvantages include the requirement for a propellant control system and heat transfer to a pintle injector element. Major concerns

in early experiments included optimization of flow control and injector design, integration of the variable area injector with the thrust control system, leakage around the pintle injector, and maintaining a specific mixture ratio for a particular thrust. Most of the problems were rectified by incorporating flow control valves in the propellant lines. In this way, both an appropriate injection pressure drop and a controlled mixture ratio were possible. Performance efficiency may not be as high as with a multielement injector.

H. Summary: Hydrodynamically Dissipative Injectors

The hydrodynamically dissipative injector uses fluid dynamics to improve the impedance across the injector. Swirling vortex tubes are the most common method and enable deep throttling by altering the discharge coefficient. The major advantage of this method is that the system remains simple because there are no moving parts in the injector. Although there is limited work in this area, an analytical framework allows the design of a two-channel hydrodynamically dissipative injector, and more specifically, a tangential-entry dual-inlet swirl injector. Throttling behavior is quantified not only by mass flow variation, but also by variations in injector discharge coefficient. A vortex tube is formed inside an injector element by considering element design and managing preinjection swirl flow. The theory shows how controlling the hydraulics inside the injector element influences the discharge coefficient.

IV. Conclusions

LREs are generally designed for fixed thrust operation with small variations about the design point for throttling. There are many applications where variable thrust is required, however, including planetary entry and descent, space rendezvous, orbital maneuvering, including orientation and stabilization in space, and hovering and hazard avoidance during planetary landing. This paper reviewed the methods for throttling LREs beginning with the pioneering work in the 1930s.

Acknowledgments

The authors are very grateful for the assistance of Dianne Moore and the librarians from the Redstone Scientific Information Center and Amy High from the Air Force Inst. of Technology academic library. The authors also thank Huaguang Li for graphic services and Anna Creese for editing services.

References

- [1] "The Vision for Space Exploration," NASA NP-2004-01-334-HQ, Washington, D.C., 2004.
- [2] "NASA Authorization Act of 2005," Senate and House of Representatives, Rept. No. 119 Stat. 2895, Washington, D.C., 16 Dec. 2005.
- [3] Sutton, G. P., *History of Liquid Propellant Rocket Engines*, AIAA, Reston, VA, 2006.
- [4] Bazarov, V. G., "Throttleable Liquid Propellant Engines Swirl Injectors for Deep Smooth Thrust Variations," AIAA Paper 94-2978, 1994.
- [5] Sutton, G. P., *Rocket Propulsion Elements An Introduction to the Engineering of Rockets*, 5th ed., Wiley, New York, 1986.
- [6] Huzel, D. K., Huang, D. H., and Seebass, A. R. (ed.), *Modern Engineering for Design of Liquid-Propellant Rocket Engines*, Progress in Astronautics and Aeronautics, Vol. 147, AIAA, Washington, D.C., 1992.
- [7] Welton, D. E., Bensky, S. M., and Hiland, J. R., "Toward the Variable-Thrust Liquid-Rocket Engine," *Astronautics and Aerospace Engineering*, Vol. 1, No. 11, 1963, p. 77.
- [8] Welton, D. E., Bensky, M. S., and Hiland, J., "Variable-Thrust Liquid Propellant Rocket Engines," AIAA Paper 63-268, 1963.
- [9] Sutton, G. P., "History of Liquid Propellant Rocket Engines in the United States," *Journal of Propulsion and Power*, Vol. 19, No. 6, 2003, pp. 978–1007. doi:10.2514/2.6942
- [10] Dornberger, W., V-2, The Viking Press, Inc., New York, 1954.
- [11] Perry, R. L., "The Antecedents of the X-1," AIAA Paper 65-453, 1965.
- [12] Walter, H., "Rept. on Rocket Power Plants Based on T-Substance," NACA TM 1170, Washington, D.C., 1947.
- [13] Rusek, J. J., "New Decomposition Catalysts and Characterization Techniques for Rocket-Grade Hydrogen Peroxide," *Journal of Propulsion and Power*, Vol. 12, No. 3, 1996, pp. 574–579. doi:10.2514/3.24071
- [14] Andrews, D., "Advantages of Hydrogen Peroxide as a Rocket Oxidant," *Journal of the British Interplanetary Society*, Vol. 43, 1990, pp. 319–328.
- [15] Walter, H., "Experience with the Application of Hydrogen Peroxide for Production of Power," *Jet Propulsion*, Vol. May–June, 1954, pp. 166–171.
- [16] Clark, J. D., *Ignition! An Informal History of Liquid Rocket Propellants*, Rutgers Univ. Press, New Brunswick, NJ, 1972.
- [17] Smith, J. R., Kay, A. L., and Creek, E. J., *German Aircraft of the Second World War*, Putman and Company Limited, London, 1972.
- [18] Myhra, D., *Secret Aircraft Designs of the Third Reich*, Schiffer Publishing Ltd., Atglen, PA, 1998.
- [19] Dressler, G. A., "Summary of Deep Throttling Rocket Engines with Emphasis on Apollo LMDE," AIAA Paper 2006-5220, 2006.
- [20] Rutkowski, E. V., "Variable-Thrust Rocket Engines," *Astronautics*, Vol. 4, No. 10, 1959, p. 40.
- [21] Amneus, J. S., "First Progress Rept. on Rocket Motor Throttling," Willow Run Research Center Engineering Research Inst., Univ. of Michigan UMM-71, Dec. 1950.
- [22] Harje, D. T., and Reardon, F. H., "Liquid Propellant Rocket Combustion Instability," NASA SP-194, Washington, D.C., 1972.
- [23] Yang, V. and Anderson, W. (eds.), *Liquid Rocket Engine Combustion Instability*, Vol. 169, AIAA, Washington, D.C., 1995.
- [24] Gill, G. S., and Nurick, W. H., "Liquid Rocket Engine Injectors," NASA SP-8089, Washington, D.C., Mar. 1976.
- [25] Zweig, F., Tuteur, F. B., Cunningham, W. J., and Bower, J. L., "The Dynamics of Throttling Hydraulic Systems," Yale Univ. Rept. 8252-R, New Haven, CT, June 1950.
- [26] Merritt, F., and Dumont, L., "Supplemental Report—Wide Range Flow Control Program," Air Force, AFRPL-TR-69-141, Edwards Air Force Base, CA, May 1969.
- [27] Relyea, L. K., "Thumper Project: Rocket Motor Throttling Tests," General Electric Company, R49A0410, Schenectady, NY, 10 Jun. 1949.
- [28] Papp, D. S., "From Project Thumper to SDI: The Role of Ballistic Missile Defense in US Security Policy," *Airpower Journal*, Vol. 1, No. 3, 1987.
- [29] Wanhainen, J. P., Antl, R. J., Hannum, N. P., and Mansour, A. H., "Throttling Characteristics of a Hydrogen-Oxygen, Regeneratively Cooled, Pump-Fed Rocket Engine," NASA, NASA TM X-1043, Washington, D.C., Dec. 1964.
- [30] "Advanced Injector Concepts Investigation Final Rept.," Aerojet Liquid Rocket Company: A Division of Aerojet General Rept. 21052-3F, April 1971.
- [31] "Advanced Injector Concepts Investigation Final Summary Rept.," Aerojet Liquid Rocket Company: A Division of Aerojet General Rept. 21052-3FS, April 1971.
- [32] Andrus, S. R., Bishop, H. L., Duckering, R. E., Gibb, J. A., Nelson, A. W., and Ransom, V. H., "Throttling and Scaling Study for Advanced Storable Engine: Part 1 of Two Parts," Air Force Rocket Propulsion Lab., AFRPL-TR-68-2, CA, Jan. 1968.
- [33] Andrus, S. R., Bishop, H. L., Gibb, J. A., and Nelson, A. W., "Throttling and Scaling Study for Advanced Storable Engine: Part 2 of Two Parts," Air Force Rocket Propulsion Lab., AFRPL-TR-68-2, CA, Jan. 1968.
- [34] Addoms, J. F., Jr., Cordova, R., and McGough, C. B., "Method of Making Composite Ultra-Thin Metal Platelet having Precisely Controlled Pattern of Flow Passages Therein," Patent No. 3,413,704, filed 26 Nov. 1965.
- [35] Wilcoxon, M. L., "RL10A-5: An Assessment of Reusability Demonstrated during the SSRT Program," AIAA Paper 96-3110, 1996.
- [36] Rachuk, V. S., Shostak, A. V., Dmitrenko, A. I., Goncharov, G. I., Hernandez, R., Starle, R. G., and Hulka, J., "Benchmark Testing of an Enhanced Operability LO2/LH2 RD-0120 Engine," AIAA Paper 96-2609, 1996.
- [37] Bradley, M. A., "SSME Off-Nominal Low Power Level Operation," AIAA Paper 1997-2685, 1997.
- [38] Anderson, B., Bradley, M. A., and Ives, J., "SSME Key Operations Demonstration," AIAA Paper 1997-2686, 1997.
- [39] Giuliano, V. J., Leonard, T. G., Adamski, W. M., and Kim, T. S., "CECE: A Deep Throttling Demonstrator Cryogenic Engine for

- NASA's Lunar Lander," AIAA Paper 2007-5480, 2007.
- [40] Giuliano, V. J., Leonard, T. G., and Kim, T. S., "Development Status of the CECE Cryogenic Deep Throttling Demonstrator Engine," *Space Propulsion 2008, 2nd International Symposium on Propulsion for Space Transportation*, Pratt and Whitney Rocketdyne, West Palm Beach, FL, 2008.
- [41] "CECE PubRel XR800-2 HR15 100-25% Power Composite, Common Extensible Cryogenic Engine at Several Power Levels," No. 07s4269-001, Image courtesy of NASA, 2007.
- [42] Kenny, R. J., "Influence of Variable Thrust Parameters on Swirl Injector Fluid Mechanics," Ph.D. Dissertation, Univ. of Alabama in Huntsville, Huntsville, AL, 2008.
- [43] Conrad, W., Hannum, N. P., and Bloomer, H. E., "Photographic Study of Liquid-Oxygen Boiling and Gas Injection in the Injector of a Chugging Rocket Engine," NASA TM X-948, Washington, D.C., Dec. 1964.
- [44] Lefebvre, A. H. and Chigier, N. (ed.), *Atomization and Sprays*, Combustion: An International Series, Taylor and Francis, Philadelphia, 1989.
- [45] Mitchell, J. P., "Technical Rept. No. 2 of Advanced Throttling Concepts Study," Pratt and Whitney Aircraft, Florida Research and Development Center, PWA FR-1045, West Palm Beach, FL, July 1964.
- [46] Mitchell, J. P., "Technical Rept. No. 3 of Advanced Throttling Concepts Study," Pratt and Whitney Aircraft, Florida Research and Development Center, PWA FR-1108, West Palm Beach, FL, 15 Sept. 1964.
- [47] Mitchell, J. P., "Technical Rept. No. 4 of Advanced Throttling Concepts Study," Pratt and Whitney Aircraft, Florida Research and Development Center, PWA FR-1231, West Palm Beach, FL, 15 Dec. 1964.
- [48] Zettle, E. V., Riebling, R. W., and Clapp, S. D., "Chamber Technology for Space-Storable Propellants," *AIAA Joint Propulsion Specialists Conference*, AIAA, New York, 1965.
- [49] Nagai, C. K., Bartlett, R. C., Knight, R. M., and Clapp, S. D., "Chamber Technology for the Space Storable OF₂: MMH Propellant Combination," AIAA Paper 66-623, 1966.
- [50] "Final Rept., Chamber Technology for Space Storable Propellants," NASA CR-110644, Canoga Park, CA, Sept. 1969.
- [51] Burry, R. V. and Pauckert, R. P., "Engine System Designs for Space Storable Propellants," AIAA Paper 68-615, 1968.
- [52] Ingebo, R. D., "Drop-Size Distributions for Impinging-Jet Breakup in Airstreams Simulating the Velocity Conditions in Rocket Combustors," NACA TN 4222, Washington, D.C., Mar. 1958.
- [53] Rupe, J. H., "The Liquid-Phase Mixing of a Pair of Impinging Streams," Jet Propulsion Lab., California Inst. of Technology, JPL-PR-20-195, 6 Aug. 1953.
- [54] Atherton, R. R., "Advanced Cryogenic Rocket Engine Program Staged Combustion Concept, Final Rept., Vol I," U. S. Air Force, AFRPL-TR-67-298-VOL I, Edwards, CA, Dec. 1967.
- [55] Atherton, R. R., "Advanced Cryogenic Rocket Engine Program Staged Combustion Concept, Final Rept., Vol II," U. S. Air Force, AFRPL-TR-67-298-VOL II, Edwards, CA, Dec. 1967.
- [56] Atherton, R. R., "Advanced Cryogenic Rocket Engine Program Staged Combustion Concept, Final Rept., Vol III," U. S. Air Force, AFRPL-TR-67-298-VOL III, Edwards, CA, Dec. 1967.
- [57] Atherton, R. R., "Air Force Reusable Rocket Engine Program XLR129-P-1 First Annual Rept., Vol I," U. S. Air Force, AFRPL-TR-69-3-Vol I, Edwards, CA, Jan. 1969.
- [58] Atherton, R. R., "Air Force Reusable Rocket Engine Program XLR129-P-1 First Annual Rept., Vol II," U. S. Air Force, AFRPL-TR-69-3-Vol II, Edwards, CA, Jan. 1969.
- [59] Atherton, R. R., "Air Force Reusable Rocket Engine Program XLR129-P-1 First Annual Rept., Vol III," U. S. Air Force, AFRPL-TR-69-3-Vol III, Edwards, CA, Jan. 1969.
- [60] Atherton, R. R., "Air Force Reusable Rocket Engine Program XLR129-P-1 Engine Performance," U. S. Air Force, AFRPL-TR-69-19, Edwards, CA, Apr. 1969.
- [61] Atherton, R. R., "Air Force Reusable Rocket Engine Program XLR129-P-1 Demonstrator Engine Design, Vol 1," U. S. Air Force, AFRPL-TR-70-6 Vol I, Edwards, CA, Apr. 1970.
- [62] Atherton, R. R., "Air Force Reusable Rocket Engine Program XLR129-P-1 Demonstrator Engine Design, Vol 3," U. S. Air Force, AFRPL-TR-70-6 Vol 3, Edwards, CA, Apr. 1970.
- [63] Atherton, R. R., "Air Force Reusable Rocket Engine Program XLR129-P-1 Final Rept., Vol I," U. S. Air Force, AFRPL-TR-71-1-Vol I, Edwards, CA, Jan. 1971.
- [64] Atherton, R. R., "Air Force Reusable Rocket Engine Program XLR129-P-1 Final Rept., Vol II," U. S. Air Force, AFRPL-TR-71-1-Vol II, Edwards, CA, Jan. 1971.
- [65] Atherton, R. R., "Air Force Reusable Rocket Engine Program XLR129-P-1 Final Rept., Vol III," U. S. Air Force, AFRPL-TR-71-1-Vol III, Edwards, CA, Jan. 1971.
- [66] Hankins, R. A., and Yankovich, M., "Throtttable [sic] Primary Injector for Staged Combustion Engine," U. S. Air Force, AFRL-TR-70-40, Edwards, CA, Jan. 1971.
- [67] Masters, A., "Advanced Expander Test Bed Program," AIAA Paper 90-3708, 1990.
- [68] Masters, A. I., and Mitchell, J. C., "Advanced Expander Test Bed Program: Final Annual Technical Progress Rept.," NASA CR 187082, West Palm Beach, FL, Apr. 1991.
- [69] Masters, A. I., and Mitchell, J. C., "Advanced Expander Test Bed Program: Preliminary Design Review Rept.," NASA CR 187081, West Palm Beach, FL, May 1991.
- [70] Masters, A. I., and Tabata, W. K., "Design of an Advanced Expander Test Bed," AIAA Paper 91-3437, 1991.
- [71] Riccardi, D. P., and Mitchell, J. P., "Advanced Expander Test Bed Program: Second Annual Technical Progress Rept.," NASA CR 189130, West Palm Beach, FL, Mar. 1992.
- [72] Mitchell, J. C., and Tabata, W. K., "Design of an Advanced Expander Test Bed," AIAA Paper 93-2133, 1993.
- [73] Riccardi, D. P., and Mitchell, J. C., "Advanced Expander Test Bed Program: Annual Technical Progress Rept. for 1992," NASA CR 191049, Jan. 1993.
- [74] Morrell, G., "Rocket Thrust Variation with Foamed Liquid Propellants," NACA RM-E56K27, Washington, D.C., 26 Feb. 1957.
- [75] Mitchell, J. P., "Final Rept. of Advanced Throttling Concepts Study," Pratt & Whitney Aircraft, Florida Research and Development Center, PWA FR-1279, West Palm Beach, FL, 19 Mar. 1965.
- [76] Rivard, J. G., "New Techniques for Throttleable Bipropellant Rocket Engines," AIAA Paper No. 65-560, 1965.
- [77] "CPIA/M5 Liquid Propellant Engine Manual," CPIA, CPIA M5, Columbia, MD, Feb. 1996.
- [78] Hammock, W. R., Jr., Currie, E. C., and Fisher, A. E., "Apollo Experience Rept.: Descent Propulsion System," NASA TN D-7143, Washington, D.C., March 1973.
- [79] Ruddock, S., and McCrea, J., "Feasibility Study and Performance Modeling of a Throttleable Attitude Control Thruster," Bachelor of Engineering with Honors, Univ. of Bristol, Bristol, United Kingdom, 1991.
- [80] Sutton, G. P., "History of Liquid Propellant Rocket Engines in Russia, Formerly Soviet Union," *Journal of Propulsion and Power*, Vol. 19, No. 6, 2003, pp. 1008-1037. doi:10.2514/2.6943
- [81] Diem, H. G., "Advanced Thrust Chamber for Space Maneuvering Propulsion Third Quarterly Rept.," U. S. Air Force, AFRPL-TR-67-78, Edwards Air Force Base, CA, Mar. 1967.
- [82] Wiswell, R. L., "Advanced Maneuvering Propulsion Technology Program (Second Quarterly Progress Rept.)," Air Force Rocket Propulsion Lab., AFRPL-TR-68-20, Canoga Park, CA, May 1968.
- [83] Wiswell, R. L., "Advanced Maneuvering Propulsion Technology Program (Third Quarterly Progress Rept.)," Air Force Rocket Propulsion Lab., AFRPL-TR-68-154, Canoga Park, CA, Sept. 1968.
- [84] Wiswell, R. L., "Advanced Maneuvering Propulsion Technology Program (Fourth Quarterly Progress Rept.)," Air Force Rocket Propulsion Lab., AFRPL-TR-68-221, Canoga Park, CA, Dec. 1968.
- [85] Wiswell, R. L., "Advanced Maneuvering Propulsion Technology Program (Fifth Quarterly Progress Rept.)," Air Force Rocket Propulsion Lab., AFRPL-TR-69-47, Canoga Park, CA, Mar. 1969.
- [86] Wiswell, R. L., "Advanced Maneuvering Propulsion Technology Program (Seventh Quarterly Progress Rept.)," Air Force Rocket Propulsion Lab., AFRPL-TR-69-189, Canoga Park, CA, Sept. 1969.
- [87] Gunston, B., *World Encyclopedia of Aero Engines: from the Pioneers to the Present Day*, The History Press Ltd., Great Britain, 2007.
- [88] Werrell, K. P., "The Evolution of the Cruise Missile," Air Univ., Maxwell Air Force Base, AL, Sept. 1985.
- [89] Brunk, W. E., and Flaherty, R. J., "Methods and Velocity Requirements for the Rendezvous of Satellites in Circumplanetary Orbits," NASA TN D-81, Washington, D.C., Oct. 1959.
- [90] Hord, R. A., and Durling, B. J., "Analysis of a Linear System for Variable-Thrust Control in the Terminal Phase of Rendezvous," NASA TN D-953, Washington, D.C., Sept. 1961.
- [91] Carey, L., "Dual-Mode, 100:1 Thrust Modulation Rocket Engine," *Journal of Spacecraft and Rockets*, Vol. 5, No. 2, 1968, pp. 168-172. doi:10.2514/3.29210
- [92] Lawrence, L., Jr., Nesbitt, M. W., Huse, A. K., and Olson, D., "Interim Engineering Rept. on 2000 Pound Acid Aniline Variable Thrust

- Liquid Propellant Rocket Engine,” Reaction Motors, Inc., RMI-205N-2, Dover, NJ, 22 Aug. 1947.
- [93] Gunter, F. L., and Fahrenheit, F. E., “Final Rept. on a Study of Rocket Thrust Control by Gas Injection,” Massachusetts Inst. of Technology Naval Supersonic Lab., Technical Rept. 448, Cambridge, MA, May 1961.
- [94] Martin, A. I., “The Aerodynamic Variable Nozzle,” *Journal of the Aeronautical Sciences*, Vol. 24, No. 5, 1957, p. 357.
- [95] “F-1 Thrust Vector Control Study,” Rocketdyne Engineering, R-1717, 28 Oct. 1959.
- [96] Riviere, R. R., “An Analytical Study on Efficiency of Variable Thrust Liquid Rocket Engines,” U.S. Army, RP-TM-61-1, Huntsville, AL, 12 Sept. 1961.
- [97] “Proposed 5,000 Pound Variable Thrust Engine Development Program,” Reaction Motors, Inc., Oct. 1950.
- [98] Fredrickson, H., Rice, P. J., and Amneus, J. S., “Second Progress Rept. on Rocket Motor Throttling,” Willow Run Research Center Engineering Research Inst., Univ. of Michigan, UMM-89, Jan. 1962.
- [99] Tomazic, W. A., “Rocket-Engine Throttling,” NACA RM E55J20, Cleveland, OH, Dec. 1955.
- [100] Elverum, G., Jr., Staudhammer, P., Miller, J., and Hoffman, A., “The Descent Engine for the Lunar Module,” *AIAA 3rd Propulsion Joint Specialist Conference*, AIAA Paper 67-521, 1967.
- [101] Gilroy, R., and Sackheim, R., “The Lunar Module Descent Engine: A Historical Summary,” AIAA Paper 89-2385, 1989.
- [102] Dressler, G. A., “The Deep Throttling Pintle Injector: History, Technology and Application to Near-Term Programs,” *53rd JANNAF Propulsion Meeting*, JANNAF, Washington, D.C., 2005.
- [103] Bennett, F. V., “Apollo Experience Report—Mission Planning for Lunar Module Descent and Ascent,” NASA TN D-6846, Washington, D.C., Jun. 1972.
- [104] Johnson, R. J., Boyd, B. R., and Smith, T. H., “Application of the MIRA 150A Variable Thrust Rocket Engine to Manned Lunar Exploration Flying Systems,” AIAA Paper 67-505, 1967.
- [105] Johnson, R. J., Boyd, B. R., and Smith, T. H., “Application of the MIRA 150A Variable-Thrust Engine to Manned Lunar Flying Systems,” *Journal of Spacecraft and Rockets*, Vol. 5, No. 7, 1968, pp. 849–851. doi:10.2514/3.29369
- [106] Shieber, H., and Rupert, R. C., “Assurance of Service Life of the MIRA 150A Variable Thrust Rocket Engine,” AIAA Paper 65-608, 1965.
- [107] Shieber, H., and Rupert, R. C., “Assurance of Service Life of the MIRA 150A Variable Thrust Rocket Engine,” *Journal of Spacecraft and Rockets*, Vol. 3, No. 7, 1966, pp. 1034–1038. doi:10.2514/3.28593
- [108] Watkins, F. E., “A Design for Throttling a Gaseous Propellant, Film Cooled, Rocket Motor by Injector Area Variation,” M.S. Thesis, Air Force Inst. of Technology Air Univ., Wright–Patterson Air Force Base, OH, 1965.
- [109] Smith, C. D., III, “The Design, Construction, and Test of a Throttling System for a Gaseous Propellant Rocket Motor,” M.S. Thesis, Air Force Inst. of Technology Air Univ., Wright-Patterson Air Force Base, OH, 1966.
- [110] De Groot, F. J., “Thrust Variation of a Gaseous Propellant Rocket Engine,” M.S. Thesis, Air Force Inst. of Technology Air Univ., Wright–Patterson Air Force Base, OH, 1967.
- [111] Wernle, C. F., II, “Throttling Rocket Engine,” M.S. Thesis, Air Force Inst. of Technology Air Univ., Wright-Patterson Air Force Base, OH, 1968.
- [112] Ow, G. Y. W., “An Evaluation of Film Cooled Gaseous Hydrogen and Oxygen Rocket Engine of 100 Pounds Thrust,” M.S. Thesis, Air Force Inst. of Technology Air Univ., Wright-Patterson Air Force Base, OH, 1960.
- [113] Chianese, S. G., Majamaki, A. N., and Gavitt, K. R., “NGST TR202 Throttling Lunar Descent Pintle Engine,” *54th JANNAF Propulsion Meeting*, JANNAF, Washington, D.C., 2007.
- [114] Majamaki, A. N., Chianese, S. G., and Kim, T. S., “TR202 Deep Throttling Lunar Descent Engine Pintle Injector Technology Development Status,” *JANNAF 6th MSS/4th LPS/3rd SPS Joint Meeting*, JANNAF, Orlando, FL, 2008.
- [115] Majamaki, A. N., and Chianese, S. G., “TR202 Variable Thrust Pintle Descent/Ascent Engine (Cumulative Through Phase II, Option I),” Northrop Grumman Space Technology, NASA CR-2008-215472, Sept. 2008.
- [116] Mikhaylov, V. V., and Bazarov, V. G., “Throttled Liquid Propellant Rocket Engines (from Russian: Drosseliruyemyye Zhidkostnyye Raketnyye Dvigateli),” Rept. FTD-1D(RS)T-0960-86 Machine Translation, Wright-Patterson Air Force Base, OH (Original: Moscow), 15 Dec. 1986 (Original: 1985).
- [117] Bazarov, V., Yang, V., and Puri, P., “Design and Dynamics of Jet and Swirl Injectors,” *Liquid Rocket Thrust Chambers: Aspects of Modeling, Analysis and Design*, edited by V. Yang, M. Habiballah, J. Hulka and M. Popp, Progress in Astronautics and Aeronautics, AIAA, Vol. 200, Reston, VA, 2004, Chap. 2, pp. 19–103.
- [118] Santoro, R. J., “Demonstration of Throttleable LOX/GH₂ Injector Concepts Final Technical Rept.,” Pennsylvania State Univ., NAG8-1732, Dec. 2001.
- [119] Greene, C., Woodward, R., Pal, S., and Santoro, R., “Design and Study of a LOX/GH₂ Throttleable Swirl Injector for Rocket Applications,” *38th JANNAF Combustion Subcommittee Meeting*, Publ-712, Vol. 1, Chemical Propulsion Information Agency, Destin, FL, 2002.

E. Kim
Associate Editor